

SUPERNOVA: DISASTER PREPAREDNESS PLAN

James A. Marusek

30 April 2004

(Disclaimer: The next major cataclysm to engulf the Earth will thread upon a world unprepared. In general, individuals and governments will not recognize the threat even when the danger signs appear. Instead, they will marvel at the birth of a nearby supernova, unaware that it brings danger in the form of a major global cooling event. History shows the last two powerful global cooling events, the Dark Ages & the Little Ice Age, each resulted in the death of nearly half of the known world's population. This plan represents one man's opinion, or more precisely one scientist's opinion. The plan analyzes the dangers and provides methods to reduce the pain and suffering that a global cooling event will bring. I make no warranty, guarantee or claim except the dangers I describe I believe to be real and the words I lay down here were done in good faith. Your decision to adopt, emulate or modify this approach is solely - your decision.)

The root cause of global cooling is a byproduct of an exploding star, a supernova. Our solar system is currently in an active region of space producing nearby supernova events. This repeating pattern or string of nearby supernovas produce and reinvigorate Great Ice Ages. Supernovas produce Galactic Cosmic Rays (GCRs), high-energy charged particles that interact with the lower atmosphere to spawn cloud creation. A burst of GCRs produces a period of intense low cloud cover, which blocks sunlight, reflects solar radiation back out into deep space producing depressed temperatures globally. The clouds form into great storms, which move moisture to higher latitudes where it drives a buildup of solar reflective snow and ice contributing to a prolonged period of cooling.

There are some that believe, that the Great Pleistocene Ice Age has come to an end. That is not the case! We are in the middle of this Ice Age, not at its end. It will only come to an end when our solar system leaves the region of space that is a breeding ground for nearby supernova events. There are some that believe that mankind has altered Earth's environment and this will inhibit any future global cooling events. Not true! The global warming theory lacks scientific credibility; its foundation is built on quicksand.

This plan will cover the following subjects associated with global cooling events:

- Global Cooling Threat
- Direct Radiation Hazard
- Famine
- Plagues
- Crop Production
- Flooding & Storms
- Cold Weather
- Glacial Period

Whether we experience a short period of global cooling (the Dark Ages, 536-545 AD), a moderate period of global cooling (the Little Ice Age, 1315-1850 AD), or a deep cooling event (Glacial Period) lasting 50,000 years or more, the cause is from the same origin, a nearby supernova event producing GCRs. The intensity of the cooling event is dictated by Earth's proximity to the supernova, and the strength of the heliomagnetic and geomagnetic fields.

Immediacy of the Threat

The global cooling events occur approximately once per millennium. The last one occurred around 700 years ago. I think it is safe to say that the next event is already at our doorstep.

GLOBAL COOLING THREAT

The Dark Ages, Little Ice Age and Glacial Period differ only by the depth and breadth of the cooling event.

There are several lessons learned from studying past GCR induced global cooling events (Dark Ages, Little Ice Age). One source of material http://www2.sunysuffolk.edu/mandias/ia/little_ice_age.html provides a description of how the Little Ice Age affected Europe. Lessons learned include:

- * Onset of these conditions can be very abrupt and very severe.
- * A decline in food production due to:
 - Dramatic increase in days with overcast skies.
 - Decline in the intensity of sunlight.
 - Decline by several degrees in global temperature
 - Regions of massive rainfall and flooding
 - Limited regions experienced droughts
 - Shortened growing season
- * A string of major and minor famines
- * Malnutrition lead to weakened immune system. Produced influenza epidemics.
- * Reoccurrence of plagues such as the Black Plague.
- * Lack of feed for livestock
- * Parasites (i.e. fusarium nivale), which thrived under snow cover, devastated crops.
- * Grain storage in cool damp conditions produced fungus (ergot blight). Contaminated grains when consumed caused an illness (St. Anthony's Fire) producing convulsions, hallucinations, gangrenous rotting of extremities.
 - * Flooding created swamplands that became mosquito breeding grounds and introduced tropical diseases such as malaria throughout Europe.
 - * During hot summers, cold air aloft produced killer hailstorms (hailstones that could kill a cow).
 - * Higher frequency of powerful storms produced major devastations.
 - * Glacier advance swallowed up entire alpine villages.
 - * Ruptured glacial ice dams produced deadly floods.
 - * As glaciers and ice sheets formed, the landmass beneath sank under the additional weight load. The crust of the earth readjusted producing an uptick in earthquake and volcanic activity.

DIRECT RADIATION HAZARD

A nearby supernova produces a surge of GCRs, which in turn produces global cooling. The initial part of the surge will contain very high energy GCRs that can produce a direct radiation threat at the surface of the planet. The flux rate of this direct radiation hazard is unknown. It might be very mild or it might be very severe. This section will discuss this specific direct radiation hazard and provide a means to minimize its effects, should it become a significant problem.

Figure 1. Supernova Radiation Timeline

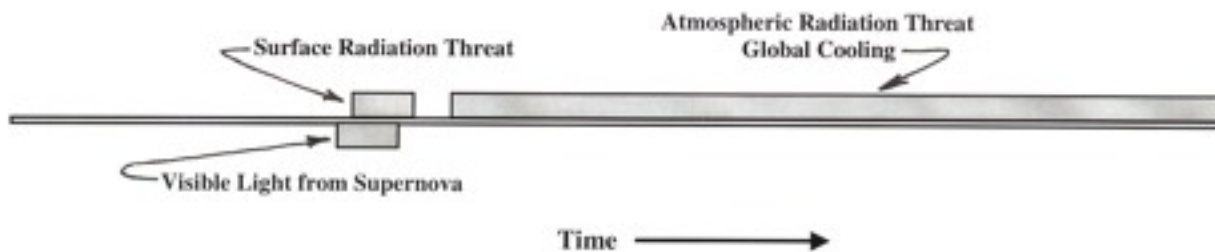

Galactic Cosmic Rays (GCRs) consists of 98% baryons and 2% electrons. The baryons comprise 87% protons (hydrogen nuclei), 12% alpha particles (helium nuclei) and about 1% heavier nuclei. The energy levels of GCRs observed in deep space generally lie in the 100 MeV (million electron volts) to 10 GeV (billion electron volts) range. Above 1 GeV, the particle flux rate decreases significantly according to a power law with an exponent of approximately 2.5.

The Earth is largely protected from cosmic radiation by the atmosphere. For example the radiation dosage in Low Earth Orbit behind an aluminum shield (1 gm/cm^3) is approximately 1 mSv/day. But at the Earth's surface, the exposure rate is approximately 1 mSv/year. As GCRs travel through Earth's atmosphere, they collide with air molecules producing a variety of secondary particles (X-Rays, Gamma Rays, Alpha Particles, Beta Particles, Neutrons and Heavy Ions). Each collision will further divide the initial energy with the daughter particles. Very high energy GCRs in the TeV (trillion electron volt) range have sufficient energy to cut through the atmosphere and produce radiation at ground level.

A single TeV cosmic ray can produce a cascade of millions of charged particles and radiation as it travels through the atmosphere. A single particle can carry the force of a baseball traveling at 100 mile per hour. Pretty impressive for a particle so small that it is not visible with the naked eye or even with the most powerful microscope. In general, scientists detect these very high energy GCRs on a very rare basis and theorize that a supernova does not have sufficient energy to produce large quantities of these particles. But I think the question is up for debate and the answer will become self evident during the next nearby supernova event. The TeV particles will be traveling at very near the speed of light. The burst of these very high energy GCRs will impact Earth at nearly the same time that a nearby supernova becomes visible in the nights sky.

Table 1. Velocity of Proton

Energy	Velocity (speed of light)
1 MeV	0.046 c
10 MeV	0.145c
100 MeV	0.429 c
1 GeV	0.875 c
10 GeV	0.996 c
100 GeV	0.999957c
1 TeV	0.99999956 c

Using Table 1, it is possible to derive an estimate for arrival time of the radiation burst. Table 2 is based on the difference in travel time between light from the supernova explosion and protons. For the fastest particles, those with energies 1 TeV and above, there is an additional particle ramp-up to release time that is not accounted for in the table. For the slowest particles, the influence from the sun's and Earth's magnetic fields will come into play and drives the particles into a non-linear path. As a result these slower particles will generally be deflected away from Earth but the few that manage to make their way to Earth will take longer to reach Earth than shown on the table.

Table 2. Initial Radiation Arrival Time after Supernova first becomes Visible

Distance from Supernova	GCR Energy (Proton)				
	1 TeV	100 GeV	10 GeV	1 GeV	100 MeV
200 lightyears	46 minutes	3 days	0.8 years	25 years	114 years
400 lightyears	1 ½ hours	6 days	1.6 years	50 years	228 years
800 lightyears	3 hours	12 ½ days	3.2 years	100 years	457 years
1,200 lightyears	4 ½ hours	19 days	4.8 years	150 years	685 years
1,600 lightyears	6 hours	25 days	6.4 years	200 years	914 years
2,000 lightyears	8 hours	31 ½ days	8 years	250 years	1,142 years
Area Affected	Earth's Surface	Earth's Surface		Earth's Atmosphere	Earth's Atmosphere

The charged particle radiation from a supernova will also be affected by the galactic magnetic field, which is typically 10^{-6} gauss. The particles will travel a slightly curved trajectory, whereas light will generally travel a straight-line path. This will add an additional delay time between when the supernova first becomes visible and the time the highest energy particles first reach Earth. This delay may add several days to the warning time to react to the radiation threat.

A few hours of additional warning time can be obtained from neutrino detection. In a supernova event, a large star explodes as the core collapses into either a neutron star or black hole. Our world exists at the atomic level. Atoms have a nucleus of protons and neutrons (analogy to the sun) with a number of electrons (analogy to the planets) spinning around the nucleus. This structure contains significant empty space, just as our solar system contains significant empty space. It has a very low density. When a large star reaches the end of its life, the core collapses into one massive dense atom with trillions upon trillions of neutrons packed tightly together. The newborn black hole or neutron star no longer exists at the atomic level. This collapse is produced when the star's protons combine with electrons to produce neutrons. This transformation releases large amounts of photons (electromagnetic energy) and neutrinos (binding energy). Neutrinos travel at the speed of light and barely interact with matter. So as the star's core begins to collapse during a supernova event and the outer shell structure begins to spread out and explode, neutrinos pass right through the shell and begin their journey. The neutrino burst will arrive at Earth approximately 18 hours before the supernova

star begins to brighten visibly. A neutrino burst can provide a useable early indicator to an imminent nearby supernova explosion.

The SuperNova Early Warning System (SNEWS) coordinates neutrino burst information to provide an early warning system for supernova events. The system resides at Department of Energy's Brookhaven National Laboratory. The system provides for an automatic early warning of a neutrino event between experimenters from around the world including Super-Kamiokande, the Sudbury Neutrino Observatory (SNO), Large Volume Detector (LVD), KamLAND, the Antarctic Muon And Neutrino Detector Array (AMANDA), Booster Neutrino Experiment (BooNE) and in the future with BOREXino Experiment, Observatory for Multiflavor Neutrino from Supernovae (OMNIS) and Ice Cube. If a neutrino burst is detected, an SNEWS alert can be manually sent to interested astronomers/astrophysicists. This includes amateur astronomers and astrophysicists. Interested parties can sign up to receive SNEWS alert messages at: <http://snews.bnl.gov/>

Hazard – Living Organisms

The particle radiation threat is different than the threat of radioactive fallout from a nuclear bomb. The fallout from a nuclear weapon produces intense X-Ray/Gamma Ray, which under very high exposure rates can cause immediate sickness and death. Particle radiation, on the other hand, cuts deeply into living organisms and release significant damage to the DNA in the cells. This damage generally becomes evident decades later producing higher incidences of cancer.

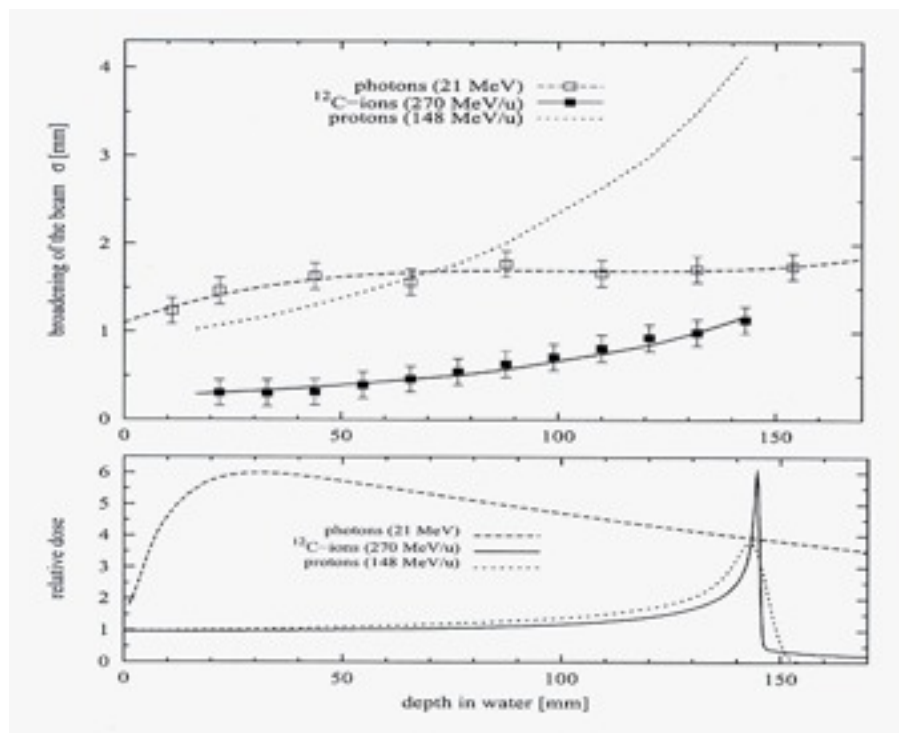

Figure 2. Radiation Penetration through Water

Source: U. Weber, Volumenkonforme Bestrahlung mit Kohlenstoffionen, PhD-Thesis, Universitat Gh Kassel, 1996.

Figure 2 defines how **protons** (the main component of GCRs), **heavy ions** (such as carbon ions) and **photons** (such as X-Rays) interact as they travel through a column of water. The heavy charged particles (protons & ions) are able to cut easily through objects and dissipate significant energy at a penetrated depth (referred to as Bragg peak). When the particles are slowed down at their penetrated depth (for 148 MeV

protons, the Bragg peak is at approximately 140 mm), the interaction time becomes larger and the value of the energy transfer is at its maximum. Now consider the above graph as a living organism. Water is a basic chemical component in humans. At the Bragg peak, a large amount of high-energy electrons are produced that cause multiple ionization events at the end of their range in a distance that corresponds to the cross section of a deoxyribonucleic acid (DNA) molecule. This ionization produces cluster damage at the DNA level. Energetic protons, neutrons and ions have a greater biological efficiency than X-rays and Gamma Rays to induce genetic damage.

Radiation is a powerful mutagen. The long-term effects of radiation are genetic alteration, cancer induction, damage to the central nervous system and peripheral neurons and accelerated aging. Densely ionizing radiation like alpha particles or heavier ions generate a greater biological effect than the same dose of X-rays. X-rays can produce isolated single and double DNA strand breaks, which can be repaired by the cells rather quickly and cleanly. Proton and ion radiation produces complex cluster damage to the DNA strands that are significantly less repairable. A macroscopic tumor may originate from only one transformed cell. If a single mutated cell survives, cancer may develop.

When several individuals within a small geological area develop cancer (primarily leukemia), the area is referred to as a cancer cluster. Several of these mysterious cancer clusters have been exhaustively researched in the U.S. over the past several years. In most cases, scientific analysis of environmental factors has been unable to identify a specific cause. Very high energy GCRs can explain this mystery. A GCR proton in the TeV energy range occasionally collides with Earth. As it passes through the atmosphere, it produces a shower of cascading radiation that can reach down to the surface of the planet. Individuals within this circle of radiation can suffer DNA damage that induces cancer (primarily leukemia), which will only become evident after the latency period of several years.

A recent NASA study shows that bone marrow is the most vulnerable part of human anatomy to this type of radiation exposure. Delicate bone marrow (within hips, shoulders, spine, thighs, sternum and skull) can be easily destroyed. If greater than 95% of the bone marrow cells are damaged, a person could run out of blood in as little as a week.

During a nearby supernova event, I believe the Earth is likely to obtain an increased flux of GCRs with energies above 10 GeV and as a result, individuals are likely to experience increased incidences of cancer, especially in children. Since these very high energy GCRs will travel at near light speeds, they will arrive during and shortly after the visible light from the supernova event. I believe the threat window will be measured in months. Some areas will experience round the clock exposure, while other areas will only see exposure periods of a few hours per day. This is a function of the portion of the globe that is being painted by direct radiation from the supernova event.

Hazard – Electronics

High-energy particle radiation can also be very deadly to electronics, especially transistors, semiconductors, integrated circuits and computer chips. Radiation damage to these elements can have a profound and shocking effect on modern society because of our complete reliance on technology.

The types of equipment that can be damaged or destroyed includes:

Energy Infrastructure: electrical power grids, power generating stations, the control systems in nuclear power plants, oil and gas delivery systems, solar cells, advance computer control systems.

Communications Infrastructure: television and radio broadcasting facilities, radios, cell phones, televisions, computers and networks, internet, digital telephone switching systems, commercial telephones, microwave and satellite communications, police scanners.

Automobiles – cars manufactured after 1985 contained a variety of electronics including engine computers, electronic ignition, fuel injection systems, anti-lock breaking systems, electronic automatic transmissions, computer controlled active suspension, four wheel steering, and electronic keys.

Transportation Infrastructure: other forms of transportation (airplanes, buses, trucks, rail, ships), road and rail signaling, gasoline pumps, global positioning systems, radar systems, navigational aids.

Economic Infrastructure: automated machinery, banking, finance industry, stock market, computer systems in factories and offices, inventory maintenance, medical pumps and monitors, medical systems, government and corporate databases, electronic controllers used in manufacturing, chemical, petroleum product industries and metallurgical industries.

GCR damage is similar to but also different from ElectroMagnetic Pulse (EMP) damage. Storing electronic equipment in a Faraday Cage for EMP protection generally will not protect this equipment from energetic protons and neutrons damage. For this type of threat, electronic equipment should be protected by mass shielding.

Shelter Design

As a GCR impacts the upper atmosphere it will collide with air molecules. These collisions will produce various types of radiation: photos (x-rays, gamma rays, visible light), electrons, and nuclear particles (neutrons, protons, ions). The kinetic energy of the original GCR will divide between these secondary particles. These particles will continue to collide as they travel through the atmosphere until they reach the Earth's surface. This cascade of secondary particles can total thousands/millions at the surface. But each individual particle will have only a small fraction of the energy, which the original GCR held. Therefore, the shielding requirements will be dramatically reduced from the threat experienced in deep space. In my opinion, the greatest hazard will be posed by energetic secondary protons, neutrons and ions, because of their capacity to produce cluster DNA damage. Therefore, the proposed shelter design is optimized towards reducing this specific threat. Compared to the other forms of radiation, the nuclear particles are like being struck by a bowling ball versus getting hit with a grain of sand. Water is an effective shield for nuclear particle radiation. Since concrete has high water content, concrete is often used as a shield for this type of radiation threat.

Many types of radiation are released by the collision of very high energy GCRs with Earth's atmosphere. If particle radiation becomes a problem, use natural and man-made sheltering to minimize risk. This can include caves, tunnels, underground shelters, underground subway systems, basements of large office buildings/parking garages, underground houses, storm shelters, bomb shelters, highway underpasses, the backside of tall buildings, and natural protection offered by large hills and mountains. Some areas may be completely shielded by the Earth. Other may see a periodic exposure of several hours per day. But some areas may experience a continuous painting of ionizing radiation. Living in shelter environments continuously for an extended period of time (i.e. a year) may be intolerable to impossible at best. I feel that it is advantageous for individuals to seek shelter in their homes if possible. As a result, I have created a shelter design that can be easily assembled in the basement of a house.

*This design will not shield against all radiation, but hopefully will limit the threat to manageable levels
The primary threats of concern are:*

- * Instantaneous neurological damage producing sudden death.*
- * Bone marrow damage.*
- * Brain damage producing permanent dementia.*
- * Increased cancer risk, primarily leukemia.*

Concept #1: Waterbed

The first design concept came to mind while I was laying on my waterbed. Water was a natural shield to nuclear radiation. Referring back to Figure 2, 150mm of water (~ 6 inches) would stop 150 MeV protons. I measured the waterbed mattress and guess what! It is 6 inches thick. So perhaps sleeping under a waterbed instead of on top would provide the needed shielding.

There are a few problems with this design. For one thing, not everyone owns a waterbed. In my mind, I could picture hundreds of millions of individuals furiously trying to purchase a waterbed simultaneously. This is a good definition of chaos. Another problem is the height of the waterbed. My wife can easily fit

under our bed but my present girth is too large to accommodate. This means that I would either have to go on a killer diet or elevate the legs of the waterbed a few inches using concrete or wooden blocks. And that means that I would have to go to the trouble of draining the waterbed first. While I was at it, I might as well replace the thin plywood base below the mattress with something more substantial (~3/4" plywood).

Concept #2: Water Storage

Then the thought crossed my mind that a waterbed is very similar to certain types of water storage containers. I decided to build a prototype of this design.



The supplies utilized in the construction are:

Quantity	Item	Total Cost
30	8" Full Concrete Blocks	\$27.00
12	8" Half Concrete Blocks	\$8.40
1	Sheet 23/32" Plywood	\$19.99
2	4" x 4" – 8' Beam	\$11.94
1	200 Gallon Aquatank	\$106.50
	Total	\$173.83

- An advantage of this design is that it is dual-use (provides radiation shielding, and afterwards provides stored drinking water).
- When filled, the 200-gallon Aquatank is approximately 10-inches thick at the center, so it would provide significant particle radiation shielding. But the thickness rolls off at the ends. Before filling, the water tank measures a perfect 4' x 8'. But after filling, the edges pull back approximately 3 ½ inches from each side. This produces a weak spot in the radiation shielding.
- The Aquatank I purchased was created using very thin plastic. When empty, it is incredibly light. I have concerns that it might be vulnerable to leaks. I feel that if my cat jumped on the water tank, its claws could easily puncture the material. I decided not to put this hypothesis to the test. If you implement this approach, I would recommend purchasing a patch kit.
- One of the major limiters to this design is availability. I feel that if million of people simultaneously attempted to purchase an Aquatank or similar product, the order volume would quickly flood the production capacity.

Concept #3: Milk Cartons and Water Balloons

While I was taking out the trash, another concept came to mind. Plastic milk cartons are design to store liquids. They are generally 8 ½ inches tall. They are readily available.

Construct the frame in Concept 2. Cover the plywood with a loose layer of 6-mil black plastic to protect shelter from water leaks. Using plastic 1-Gallon milk cartons, fill each completely with water and place them on top the plastic covered plywood. Align each set of 4 cartons such that their handles face each other. The handles are a weakness because they contain mostly air. Fill water balloons and insert several balloons to cover the handle area. Repeat the pattern until the entire sheet of plywood is covered. Place a movers strap (wide nylon cinch strap with cambuckle) around the entire collection of milk cartons to hold the mass together. (From personal experience, I recommend wearing a swimsuit when filling water balloons. Aligning the movers strap will be difficult because access from the top will be severely restricted.)



I originally liked this idea, because it promotes reutilization. **Waste not, want not!** Used milk cartons could be set-aside over the years in preparation for the next cooling event. Also, can you think of anything *cooler* than building a particle radiation mass shelter from empty milk cartons and water balloons? *Alas mon ami*, perhaps it is not meant to be! I am told that used plastic milk cartons will degrade with age. After sitting empty stored on a shelf for several years, they will become very brittle and unreliable. Also water balloon have a tendency to explode after a few days. Scratch this concept!

Layout Concept

Concept #4: 2" x 12" Construction

After letting the limitations wash through my mind for a few days, the following concept shelter began to materialize. Two limitations drove this concept: *ready availability of materials* and *maximizing the radiation shielding*. I like this design for the following reasons:

- The design provides a good 11-inches of water shielding. This thickness shields against proton secondary particles up to ~215 MeV.
- This shelter design will seat 4 and sleep 2.
- Shelter is fairly inexpensive to build. Total cost is \$138.00.
- Design is modular. Can easily expand sheltering by building more units, which I recommend. Extra space can provide sheltering for extended family members, friends and electronics.
- Another advantage of this design is the reliance on very common building materials.
- The shelter height was designed to allow a typical individual to sit upright. It provides floor space



- for insulated bedding or padding to sit on.
- This design is very stable. But in the rare event of an earthquake, it might come apart. The weight of the water will be approximately 2,000 lbs. This can create a crushing hazard. I like this particular design because by virtue that it is open, it provides an automatic pressure relief. In the event of an earthquake and the shelter collapse, the water will spill out, and the weight will be relieved.

Construct this shelter in the following manner. Begin by obtaining the following materials:

Quantity	Item	Total Cost
30	8" Full Concrete Blocks	\$27.00
12	8" Half Concrete Blocks	\$8.40
1	Sheet 23/32" Plywood	\$19.99
2	4" x 4" – 8' Beam	\$11.94
3	2" x 12" – 8' Lumber	\$38.25
1	10' x 100' Roll 6 mils Black Plastic	\$24.67
Miscellaneous Hardware	(3) #20 Common Nails, (12) 5/16" Hex Lag Screws – 3" Long, (12) 1/4" Hex Lag Screws– 1 1/2" Long, (12) 1/4" Flat Washers, (12) 5/16" Flat Washers, Pack of Wooden Shims	\$7.32
	Total	\$137.57

Select the shelter location. The shelter should be positioned in the corner of the basement that faces the supernova path. This allows side shielding by the basement block walls and earth up to grade level around the house.

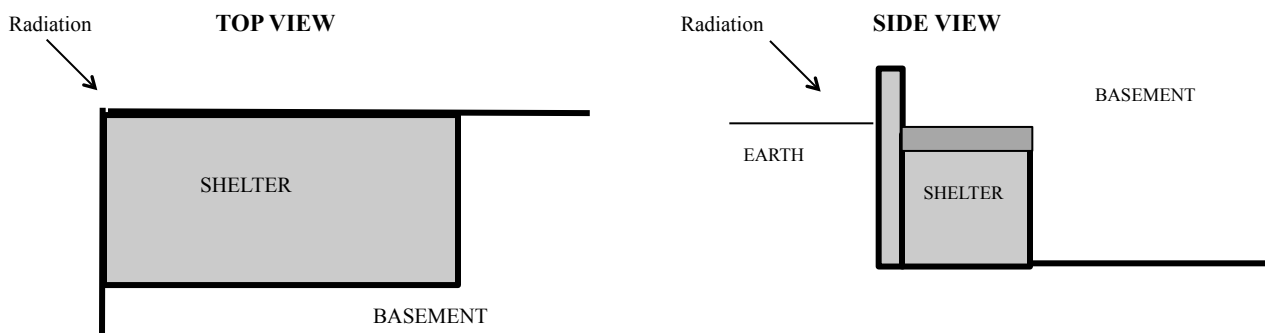

Mark a 4' x 8' area on the basement floor. Assemble the loose blocks to create two 4' wide concrete block walls. The dimensions of concrete blocks are undersized to allow for the width of mortar between blocks. A full block is 15 1/2" x 7 1/2" x 7 1/2" and a half block is 7 1/2" x 7 1/2" x 7 1/2". As a consequence, leave a little gap between blocks to compensate. Assemble each layer from the outside and work in. Start the first layer with full blocks and the next layer with half blocks on the outer edges. Repeat this pattern for the 6 layers of blocks. The pattern will look similar to this photograph:



Mark a line dividing the plywood into two 4' x 4' segments. Three wooden beams will support the structure along the middle. Select a drill bit slightly smaller than the diameter of the nails. Drill three holes in the plywood along the centerline, one for each of the three beams. The actual dimensions of a 4" x 4" beams are 3 1/2" x 3 1/2". In the plywood drill one hole 1 3/4" from the plywood edge on the marked line, one on the opposite side and a third hole dead center at 2' from the edge of the plywood.

Place the sheet of plywood on the block walls. Check that the edges of the plywood line up with the concrete block walls. Adjust the blocks, if required to achieve alignment and uniform block spacing. Place the plywood back on the ground.

Cut two of the 2" x 12" boards to exactly 8 feet in length. Cut the remaining board into two 3' 9" boards. These 4 pieces will form a perfect box whose outer dimensions are exactly 4' x 8', the dimensions of a sheet of plywood. Assemble the box using 3" long 5/16" hex lag screws with washers (3 to a side). Pre-drill a hole for each hex head screw and assemble the box. The wood edge at the bottom of the box should be flush.

Place the box made from 2" x 12" boards on the sheet of plywood and center. Draw a line on the inside of the box. Remove the box. Twelve holes will need to be drilled in the plywood as starter holes for the hex screws that will join the plywood to the box. Begin by drilling a hole on each of the 4 corners of the sheet of plywood halfway between the pencil mark and the plywood edge. Drill 1 additional starter hole in the center of each 4' side. Drill 3 additional starter holes space evenly on the 8' side. Verify the center hole is slightly offset from the drilled nail hole to avoid interference.

Place the sheet of plywood over the wooden box and center. With the edges lined up, install the 12 hex screws with washers. Flip the box over and place it atop the concrete block walls. This may take several individuals because the box will be fairly heavy at this point.

Center the plywood on the concrete blocks and level the plywood. It is critical that the plywood be level. Otherwise, the 11" of water depth cannot be achieved. Use wooden wedges or other hard material such as ceramic tiles to level the plywood above the concrete block walls.

Next cut the 3 support legs with the floor slope in mind. Measure the distance from the floor to the underside of the plywood at the 3 predrilled nail holes. Cut the 4" x 4" into three support legs. These legs will be approximately 46 1/4" in length. Check each beam for perfect fit. If a wooden beam is slightly too long, it can be sanded down to make a perfect fit using a rotary sander. If the beam is a little too short, wooden wedges can be used to take up the gap. Level each beam and nail to the plywood. Inspect the inside of the box for screw/nail penetrations and wooden splinters. Remove any defect that could puncture or cut into the plastic.

Cut a 14-foot long piece from the roll of 6-mil black plastic. Fold the sheet down the middle forming a 10' x 7' double walled liner. Place the sheet in the wooden box and center, conforming the plastic into the box walls. Fill the plastic with several gallons of water and pull on the plastic sides to smooth out and align. Verify plastic is well centered and is above the top of the wood on all sides and then fill the box to the top with water. Add 4 cups of non-scented bleach to the water to sanitize and disinfect.

Concept #5: Portable Swimming Pool
Final & Best Design

This concept is my best and final design. It offers several improvements that might be worth retrofitting into the earlier designs. My house does not have a basement; therefore many of the early designs would be difficult to work with. As a result, I continued in my efforts to refine possible designs. This one sprang from a visit to SAM's Club. I bought an ice cream bar coated in thick rich chocolate and covered in nuts. I had just sat down at an adjacent table conveniently located in the food concession area when I looked up and beheld a wonder. In front of me was an inflatable above ground pool for \$183.88. For most people, this is nothing more than a swimming pool for the young ones to play in during a sunny afternoon. But to me, this 15-foot diameter 42-inch deep pool had a secret life. Imagine mass shielding from 42 inches of water depth.

Although my house does not have a basement, it does offer a unique landscape of hills, trees, valleys, a stream and several ravines. Not far from my house is a deep ravine that blocks the view from the south, east, and west. This is an ideal shelter site because it provides significant natural shielding (like an underground cave) and will minimize direct particle radiation exposure time.

Fast nuclear particles (protons & neutrons) must be slowed down before they are captured. Light nuclei, such as hydrogen, are effective at slowing down these particles through elastic scattering. That is the reason why water (which contains hydrogen) is an effective shield. Other atoms (boron, cadmium, chlorine, iron, fluorine, lithium and potassium) are very efficient at absorbing nuclear particles once they have been slowed. Adding salt (which contains chlorine atoms) provides dramatic improvements to the efficiency of the shelter design. One of the least expensive and most commonly available salts is water softener salt. Therefore the improved design adds 200 pounds of salt to the water.

Once the nuclear particles are captured, they will release an explosion of gamma rays. In earlier designs, I ignored gamma ray radiation because they produce significantly less cellular damage than nuclear particles. But because the gamma ray burst is relatively close to the shelter occupants, it seemed wise to add gamma ray shielding to the design. The most effective gamma ray shielding materials are those with high density and high atomic numbers, such as lead, tungsten and uranium. The following table provides tenth value layer thickness for various materials. This is the thickness of the material required to cut the gamma ray exposure to 10%.

Shield Material	Tenth Value Layer (cm)	
	0.5 MeV	0.8 MeV
Lead	1.4	2.6
Copper	4.0	5.0
Iron	4.8	5.9
Aluminum	14.0	16.0
Concrete	15.0	18.0
Earth	19.0	23.0
Water	35.0	40.0
Air	29000.0	34000.0

Although from a theoretical viewpoint, lead might look like an ideal building material, from the consideration of weight, cost, availability and hazardous material; lead is very impractical. Earth on the other hand is easily available and essentially free. Two feet of earth will reduce the gamma ray exposure rate by a factor of approximately 1000. Therefore, the new shelter design incorporates this material feature.

This shelter is larger (112 sq. ft.) and more expensive (\$895) than earlier designs. But it will shelter 18 full size adults. Therefore on an individual basis the cost will be approximately \$50.00 per person. The design offers 42" of water shielding enhanced by a salt additive for nuclear particle radiation followed by two-feet of earth for gamma ray shielding.

Construct this shelter in the following manner. Begin by obtaining the following material.

PARTS LIST

Quantity	Item Description	Cost
1	15-Foot Diameter, 42 Inch Deep Portable Swimming Pool	\$183.88
189	Concrete Blocks (Full)	\$170.10
7	Concrete Blocks (Half)	\$4.90
128	Retaining Wall Concrete Blocks (16")	\$215.04
1	20' x 100' Roll, 6-mil Black Plastic Sheet	\$45.97
4	4' x 8' Sheets, 23/32" Thick Sheathing Plywood	\$79.96
12	4" x 4" – 8' Long Beams (Treated Lumber)	\$71.64
6	2" x 6" – 12' Long Lumber	\$35.34
3	2" x 6" – 8' Long Lumber	\$10.44
5	40 lb. Bags of Water Softener Salt	\$16.90
12	5/8" – 11 x 8" Long Hex Bolts	\$30.84
4	1/2" – 13 x 8" Long Hex Bolts	\$9.08
12	3/8" x 3 1/2" Long Hex Lag Screws	\$5.04
3	3/8" x 7" Long Hex Lag Screws	\$2.16
8	5/16" x 2" Long Hex Lag Screws	\$1.76
8	5/16" Washers	\$0.48
15	3/8" Washers	\$1.20
8	1/2" Washers	\$1.04
24	5/8" Washers	\$5.28
12	5/8" – 11 Nuts	\$2.76
4	1/2" – 13 Nuts	\$0.52
3	8" Hot Galvanized Spikes (large nails)	\$1.26
	TOTAL	\$895.59

Shelter construction can be separated into 2 phases. Most of the strenuous work related to shelter construction is in excavating the trench and constructing the shell from concrete blocks and retaining wall blocks. This is the first phase and can be done prior to detection of a supernova event. The shell once constructed should be fairly maintenance free and last for several hundred years. The second phase can be

delayed until a supernova threat materializes. This phase is less labor intensive. It consists of building the center supports, laying down the plywood shelter ceiling, covering the shelter with 2 feet of earth and installing and filling the pool. The phase 2 components are vulnerable to the elements. That is one of the main reasons for phasing the construction. This approach means that the shelter can for the most part be constructed under agreeable weather conditions. I can think of nothing worse than digging the shelter trench in the middle of a blinding snowstorm. Another reason why it is advantageous to start construction now is because securing all the necessary construction material will significantly reduce the time required to respond to a threat. Trying to locate this common construction material when the entire world is in a state of panic would not be what I would call a picnic.

Drawings 1-3 depict the supernova shelter (cross sectional view, top down view and side view front). Review these drawings to obtain a quick overview of the end product. The shelter is constructed in the following 15 steps:

Step 1. Excavate Site. Locate a shelter site that offers the best natural shielding. Mark off and excavate an area 9 feet wide by 16 feet long. The excavated earth should be used to raise up and level off the site area. The trench should be 5' 9" deep. The front floor of the shelter should be level with the ground immediately in front of the shelter. This might require that the excavation drive more than 16 feet into the hill. Verify the shelter floor is level and the area where the 15-foot pool will rest is level.

Step 2. Lay Foundation. Excavate a trench 8" wide by 8" deep for the foundation blocks in the floor of the shelter. Refer to Drawings 1 & 2. Put a thin layer of sand down and lay the concrete blocks down in the sand. Lay the blocks loosely as shown in Drawing 2. Leave no gap between blocks. It is important that this first layer of blocks be level because it will serve as the foundation of the structure.

Step 3. Lay Concrete Blocks. Place the first row of concrete blocks above the foundation blocks. Alternate the half block between the left and right side for each row. This will cause the blocks to overlap, which will increase the inherent strength of the structure. It will lock them into place. Next fill the blocks with pea gravel or crushed rock and tamper down. This will help to hold the loose blocks together. Repeat this process until all 6 rows of blocks are put into place above the foundation.

Step 4. Backfill Walls. Backfill the area between the concrete blocks and the trench wall with pea gravel or crushed rock. In cold climates, the ground will freeze and thaw. This force will push the block walls inward. The gravel/crushed rock will drain this moisture and bring long-term stability to the construction. Cap the gravel/crushed rock with a 3" thick layer of earth and cover this with a strip of 6-mil black plastic. This is to reduce water from draining into the gravel and undermining the construction.

Step 5. Lay Retaining Wall. Lay a row of retaining wall blocks above the concrete block wall. These blocks will slope outward and lock into place. The first row of blocks should have setback to allow the plywood to ceiling to freely be put into place. Refer to Detail #8. For the sides, this can be accomplished by starting the retaining wall blocks so they do not overlap the concrete block wall. But for the back of the shelter, the retaining wall blocks must be around 6" recessed from the outer wall of the concrete block wall. (If in doubt, lay the plywood down and use this to guide the placement of the first set of retaining wall blocks.) Lay the remaining 3 rows of retaining wall blocks. Backfill the retaining wall blocks with earth. [The retaining wall blocks are only necessary if you follow the 2-phased approach to shelter construction. If the supernova threat is imminent, and the entire shelter is being constructed at once, this step is unnecessary.]

Step 6. Construct Front Support. At this point the shell of the shelter has been constructed. It can sit idle for decades until it is needed. There is one more step to help protect the shell from caving in over the years. This step is building and installing the front support. This front support is fabricated using 4"x4" beams, which are, treated lumber. Refer to Detail #9. Begin by making very exact measurement of the front of the shelter. Cut 2 beams to the width of the shelter front. This should be approximately 85 1/4". Next cut three beams to the shelter height minus the thickness of two beams. This should be approximately 45" - 7" = 38". On the 85 1/4" footer, mark the centerline and then mark the spot 1 3/4" inches from each end and the spot that is dead center. This will give three drill locations on the footer. Drill three holes that are the size of the

hex lag screws (3/8"). Verify the lag screws will freely move through the holes. On one side of the 3 vertical beams drill a starter hole in the end center. Refer to Detail #1. Mark an "X" on the beam. Where the lines cross is the center. Drill a hole at the center with a drill bit smaller than the lag screw. Attach each of the vertical beams to the footer using a 3/8" x 7" hex lag screw and washer. Next take the 85 1/4" header beam and mark the center locations in the same manner as the footer. Place the header on the vertical beams and clamp them together from the sides. Drill a starter hole slightly smaller than the width of the nail (8" hot galvanized spike). The drill depth should be approximately 8" deep. (Treated lumber can be particularly tough and pre-drilling the holes is advantageous.) Pound the nail into place to join the header to the vertical beam. Repeat for all three vertical beams. The Front Support is not completed. Place this support into the front edge of the shelter. [Phase 1 of the construction is now complete.]

Step 7. Cutting Lumber for Center Support Structures. This step begins the second phase of shelter construction. Begin this phase when a nearby supernova event is detected. The shelter will have 2 center supports. Refer to Detail #6 and Drawing 1. Take each of the six 2"x6"x12' long pieces of lumber and cut each to exactly 12 feet in length. Four of the 2"x6" boards will be used as headers and two will be used as footers. On each piece of lumber mark the boards in the center in accordance with Detail #2. This will be the connecting location for the headers and footers. 4"x4" beams will be used as the supports for the structure. Twelve 43" long beams will be required. Cut these beams. On one side of each beam, mark the center of the beam in accordance with Detail #1. This will be the connecting location for the footer. On the other side of the beam, mark along the centerline in accordance with Detail #3. This will be the connecting location for the headers.

Step 8. Drilling Lumber for Center Support Structures. Take the 4 boards that will be used for headers and drill marked 5/8" holes. Verify the 5/8"-11x8" hex head bolts will freely travel through these holes. Take the 2 boards that will be used as footers and drill marked 3/8" holes. Verify the 3/8"x 3 1/2" long hex lag screws will freely travel through these holes. Next take the twelve 4"x4" beams and drill a 5/8" hole on the header end of each beam. Refer to Detail #3. Verify the 5/8"-11x8" long hex head bolts will freely travel through the holes. On the other end of each beam drill a starter hole smaller than 3/8".

Step 9. Assemble Center Support Structures. Join the footers to the 4"x4" beams using 3/8" x 3 1/2" hex lag screws and 3/8" washers. Refer to Detail #4. Join the two headers (one on each side) to each beam using a 5/8"-11x8" hex head bolt, two sets of 5/8" washers and a 5/8"-11 nut. Refer to Detail #5. A 2"x6" piece of lumber is not always straight. This lumber can be straightened during the joining process. Start at one end and bolt the headers to the beam. Bolt the next beam. On the third beam, raise or lower the end of the 2"x6" to align the board and bolt these together. Work down the remainder of the headers until the entire assembly is completed. The two header boards should be fairly straight.

Step 10. Install Center Support Structures. Place the Center Support Structures in the shelter. Align these supports in accordance with Detail #7.

Step 11. Install Plywood Ceiling. Chalk a centerline across a 4'x8'- 23/32" thick sheet of plywood and cut the plywood to create two 2'x8' sheets. Install the plywood ceiling on the block wall and center. Begin with the 2'x8' sheet. Place this sheet flush with the front of the shelter concrete blocks. It should overhang each sidewall approximately 5.375". Align and nail the plywood to the center support structures. Refer to Detail #8. Place the three 4'x8' sheets of plywood down one at a time, center and nail into place.

Step 12. Install Shelter Front Face. Refer to Detail #10. Place a 4"x4" – 8' long beam over the 2'x8' sheet of plywood at the front edge of the shelter. Offset this beam in by the width of a sheet of plywood (23/32"). Clamp the beam in place. Drill four 1/2" holes evenly spaced and centered along the beam. Insert a 1/2"-13x8" hex head bolt, 1/2" washer, through each hole from the bottom and join using a 1/2" washer and 1/2"-13 nut at the top. (The hex head bolt is mounted from underneath to prevent individuals from gashing their head on it when they leave and enter the shelter.) Next install the other 2'x8' sheet of plywood vertically. Use eight 5/16" x 2" long hex lag screws & eight washers to attach the plywood to the base of the 4"x4" beam.

Step 13. Cover Shelter with Earth. Begin to cover the structure with 2 feet of earth. The front face of the structure will need added support braces. Refer to Drawing 3. Three 2"x6"-8 foot long boards will be used as braces. On one end of each board, cut a 45-degree angle. Place the flat end into the ground and nail the 45-degree end to the 2'x8' sheet of plywood used as the front face. The boards should be nailed as the shelter is almost completely covered with earth. Level the earth above the shelter to accept the 15' diameter pool. Cover the area with one continuous sheet of 6-mil black plastic.

Step 14. Install the Pool. Locate and center the 15' diameter pool. It should be placed as far forward as possible so that most of the shelter area is protected by the pool. The unfilled pool will be slightly larger than the filled pool because as the pool fills it pulls back from the edges as it raises up. It may be necessary to place a piece of plywood at the front end of the pool and hold it temporarily in place until the pool is completely filled. Once the pool is nearly filled, add 200 pounds of salt to the water. It may take several hours for the salt to dissolve. (In addition to the added radiation protection, the salt will also add some freezing protection to the pool).

Step 15. Sandbags. It may be advantageous to add some gamma ray protection to the front of the shelter. This can be accomplished with sandbags or by moving some earth in front of the shelter.

Drawing 1 Supernova Shelter (Cross Section View)

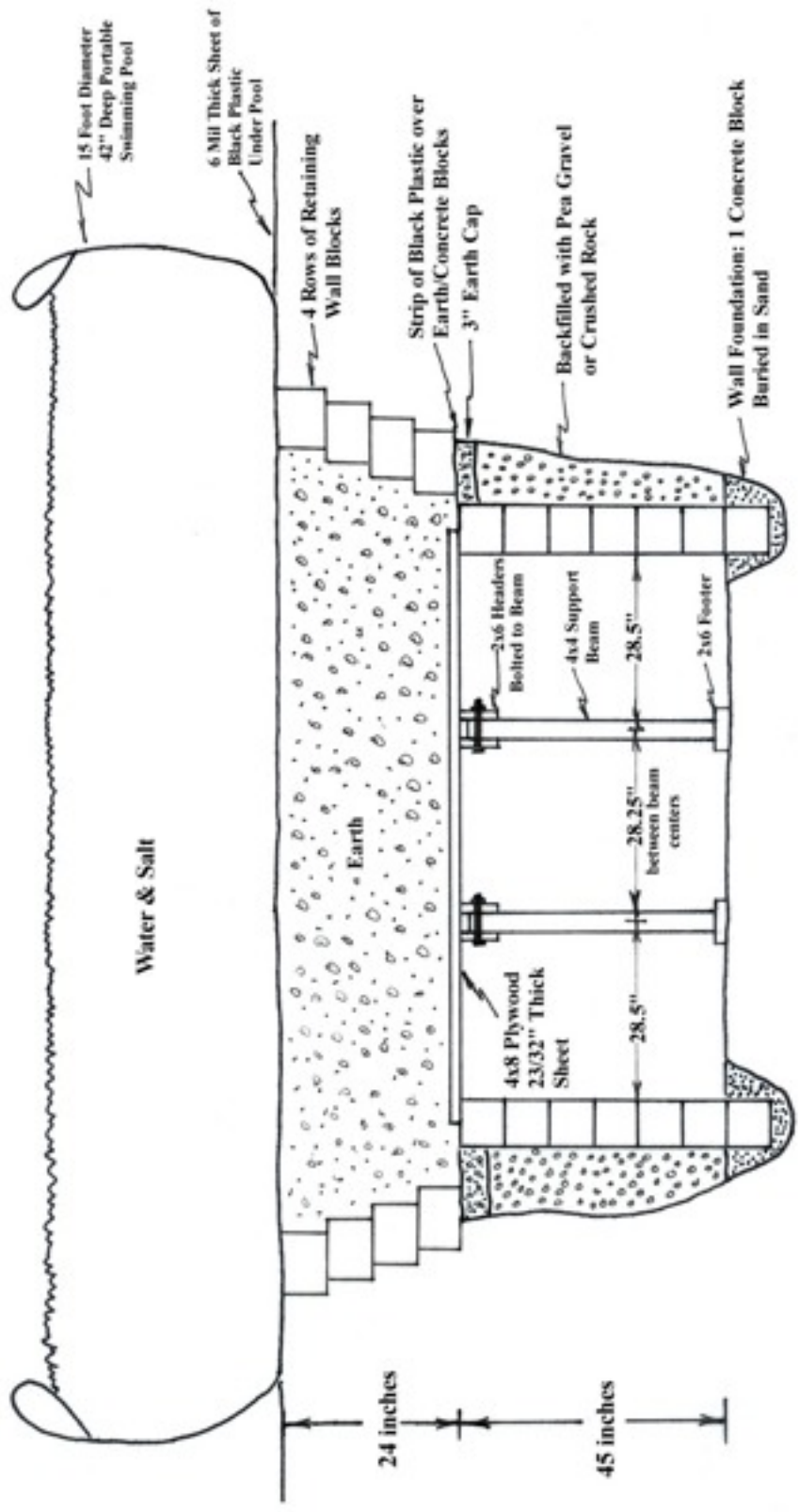

Drawing 2 Supernova Shelter (Top Down View of Shelter Walls)

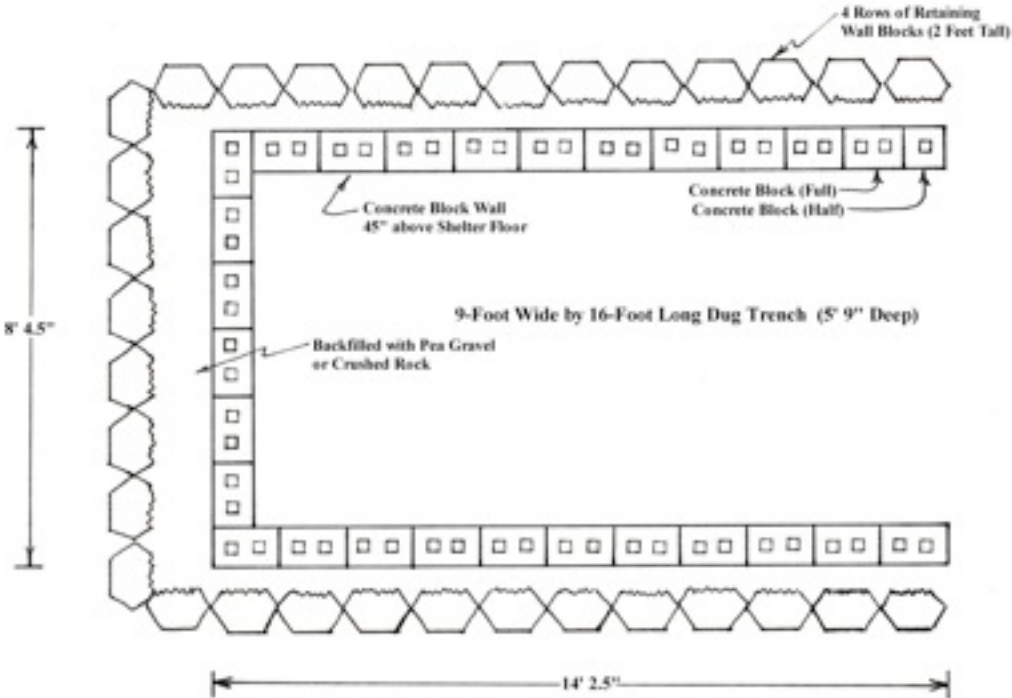

Drawing 3 Supernova Shelter (Side View Front)

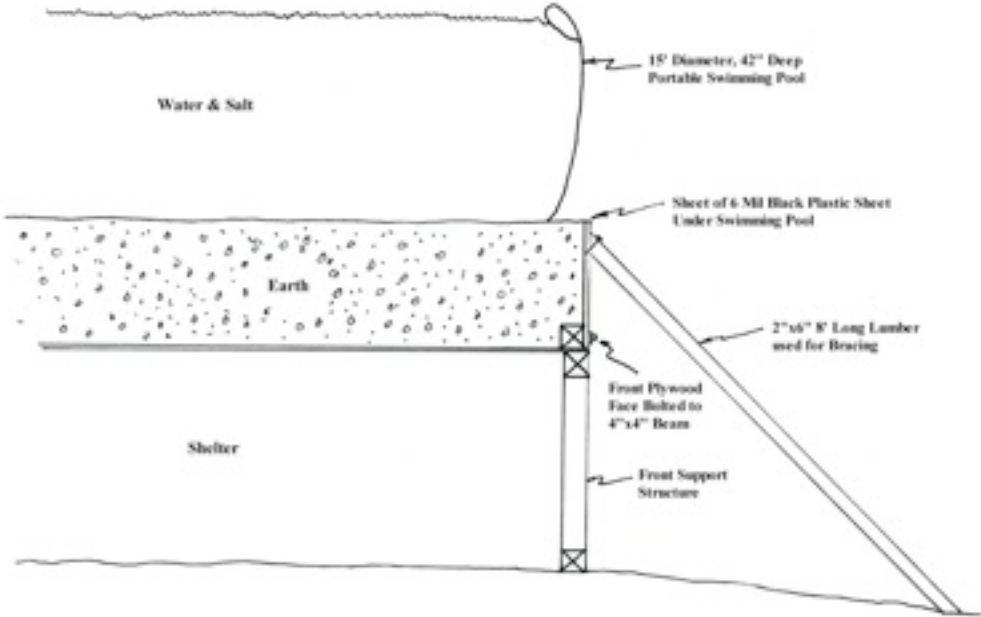

Detail #1
Determining Footer
Drill Location on End of
4" x 4" Beam



Detail #2
Drill Location on 12 Foot Long 2" x 6" Lumber



Detail #3
Determining Header Drill Location
on Beams

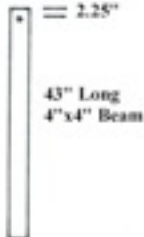

Detail #4
Attaching Footer
to Beam

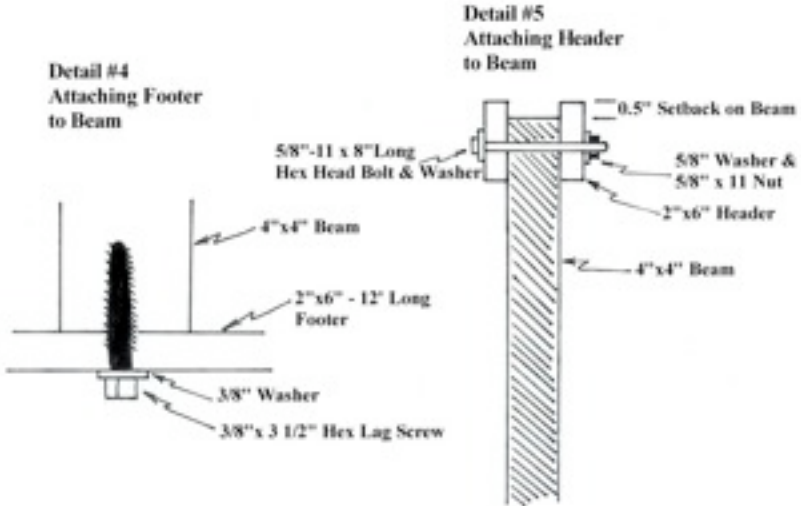

Detail #6
Center Support Structure

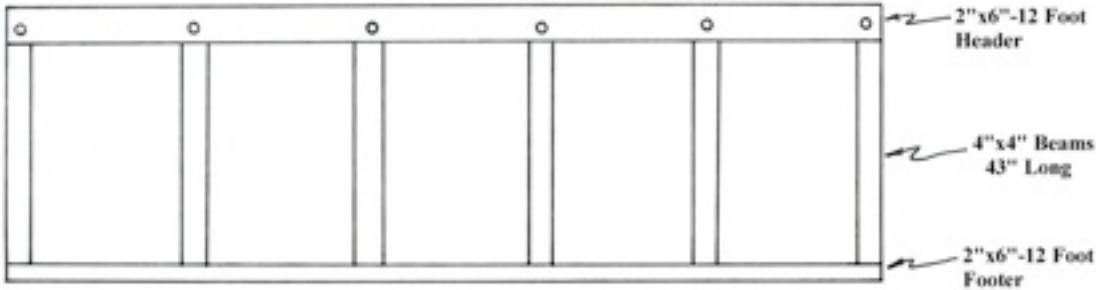

Detail #7
Location of Center Support Structures

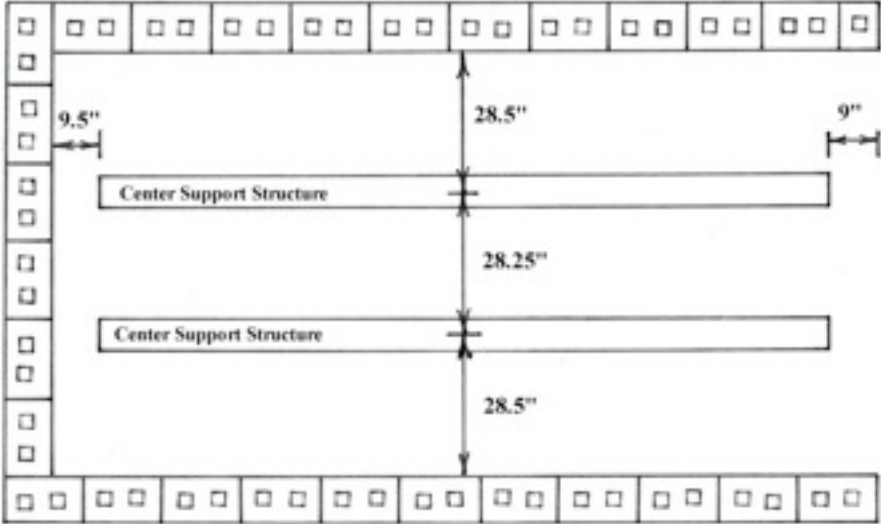

Detail #8
Plywood Centering on Block Wall

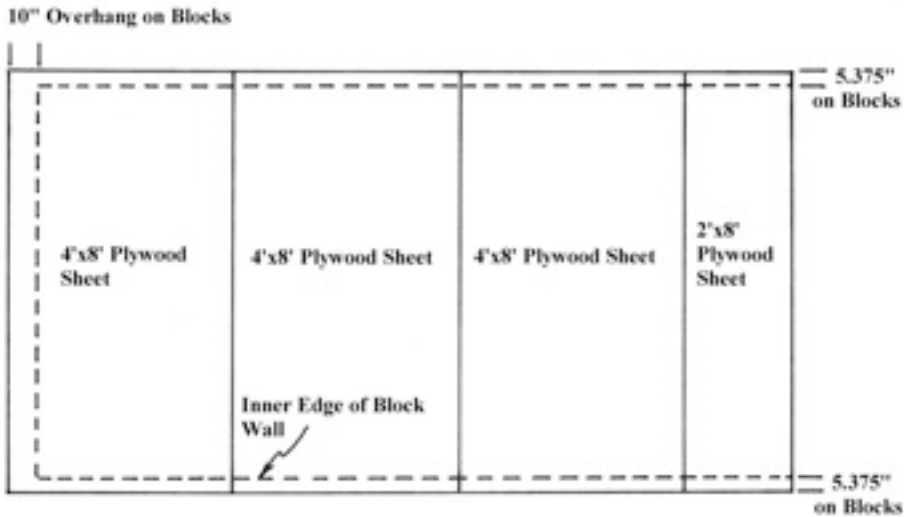

Detail #9
Front Support Structure

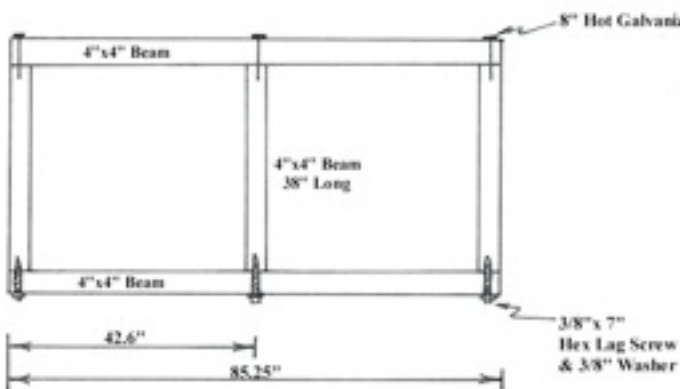

Detail #10
Attaching Front Support Structure to Shelter Plywood Ceiling & Front Face

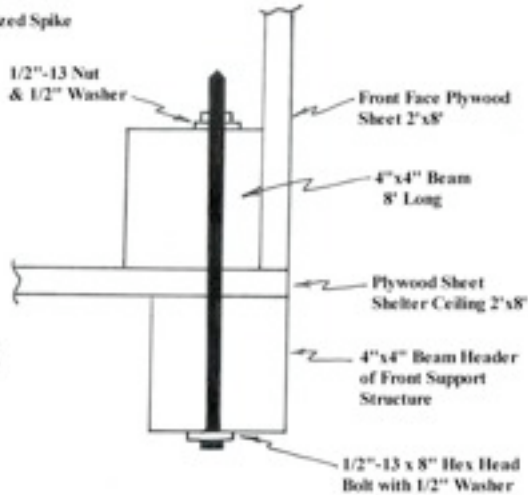

I thought it might be worthwhile to discuss some of the practical problems, which might be encountered during shelter construction. These include lighting, electricity, water and drill bits.

My potential building site is approximately 500 feet from my house. This distance though not great can cause some real construction problems. If electricity cannot be secured at the construction site, then excavation & construction may be restricted to daylight only. Also cutting and drilling operations would need to be restricted to the nearest source of electricity (i.e. home). Once a real threat materializes, time will be of the essence. Working at night with only a flashlight would be ineffective. The options available to me are to purchase a portable electrical generator or construct an emergency extension cord.

Many extension cords are not designed to be ganged together to create a 500-foot extension cord. If you try, you are likely to continually blow a circuit breaker in the house due to excessive line loss. If you have some experience working with electrical wiring, it may possible to fabricate an emergency homemade extension cord that would limit the voltage drop under load. Line loss can be minimized by reducing the number of connections and by using larger gauge wiring. This is a photograph of a 500-foot emergency extension cord, which I put together and tested with a circular saw. It uses two 250-foot spools of 12/2 copper electrical wire with ground, a GFCI protected outlet, a PVC outlet box, 2 male and 1 female rubber guard plug connectors with cable strain relief. I capped one end of the PVC box and I filled the pipe & wiring on the other end with silicon caulking. For safety sake, I checked out the finished wiring with a voltmeter to preclude shorts prior to use. This emergency extension cord is not designed for use in rain or to drive heavy equipment over. (Warning – electricity can kill. Unless you are familiar with electrical house wiring and are a competent craftsman, this option may pose significant hazards and risks.)

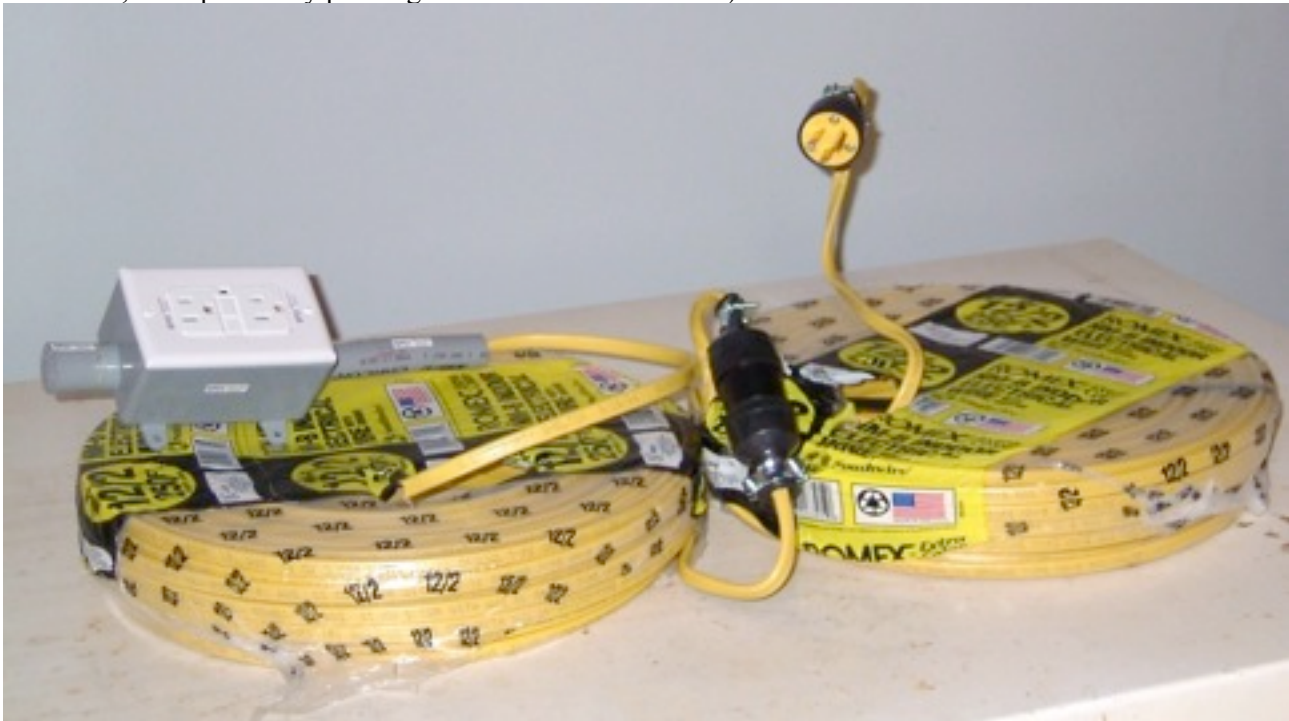

Most of the drill bits used in this construction are fairly common. The only one that might be difficult to secure is the 8-inch long 5/8" drill bit used in Detail #10. If this drill bit cannot be secured, the holes may be drilled through the individual boards one piece at a time.

Unless water can be secured at the construction site, it must be trucked in or hauled in by hand. Five hundred feet can be a very long distance to move water. It might be difficult to secure that length of water hoses on short notice for the filling operation. I took the approach of buying the hoses in advance when they were on sale (four 125-foot hoses, 5/8" diameter). The hose diameter should be large to minimize water pressure drop.

Scenario Walk-Thru

If you have signed up to receive a SNEWS alert, the first indication of a supernova event in progress might be the receipt of a SNEWS email. The initial email might be very minimal, only consisting of an indication of a neutrino burst and an event time in UTC (Universal Time Code). Most supernova events in our galaxy are far away and will not pose a threat. It is estimated that a supernova occurs in the Milky Way galaxy around every 50 years. A nearby supernova producing a global cooling event occurs around every 1,000 years. So in general, an SNEWS alert will be a benign event. Print out a hardcopy of the alert.

At this stage, some actions that might be taken are to alert friends, families and associates that a supernova event may be underway. Amateur astronomers can begin to set up their telescopes. If you possess a Geiger counter, it's a good time to install batteries in the unit. Also identify a nearby shelter to relocate to if a threat materializes.

One of the first indications that will point to a nearby supernova event will be the intensity of the neutrino burst rate. On February 23, 1987, a distant Type II supernova was detected in the Large Magellanic Cloud, 160,000 light years from Earth. A deep mine neutrino detection facility, Kamiokande in Japan detected 11 neutrino events. At the same time a similar facility at the Morton-Thiokol salt mine in Ohio detected 8 neutrino events. The neutrino burst occurred 18 hours before the first optical sighting of the supernova. A close supernova will produce tens of thousands of neutrino events and may saturate detection equipment.

As the event progresses, additional information will be disseminated. The supernova will become visible and the position will become known. The star or star clusters of concern will reside within 2,000 light years from Earth, will contain short-lived blue stars of the spectral type O (20-100 solar masses) or blue-white stars of spectral type B (3-20 solar masses), which will have formed about 65 million years ago. (One example might be Pleiades, an open star cluster also known as the Seven Sisters and Messier 45, which is located 400 light years from Earth.) Once the star begins to brighten, the location will begin to get locked down. If the declination is +45 degrees or greater, the high-energy radiation threat will be greater in the Northern Hemisphere. If the declination is -45 degrees or below, the radiation threat will be greater in the Southern Hemisphere. If the value is between +45 degrees and -45 degrees, it will affect both hemispheres.

The burst of high energy GCRs will produce several effects that can portend the level of danger. The radiation will in quick order damage and degrade satellites. Since television stations transmit feeds over satellites. Non-local feeds will be knocked off the air. Messages like "Experiencing Technical Difficulties" will begin popping-up on TV programming. The radiation will also produce unusual impressions in the sky. Strange auroras will be visible in the night's sky. Astronauts sometimes experience flashes of light as radiation particles pass into the eyeballs. Individuals on Earth might also experience this sensation.

If the supernova is within 2,000 light years from Earth and is in a direct line of sight from your location, I would treat it as a potential threat. Gather a radiation detector and a portable radio and relocate to a shelter. Safety first! A deep shelter is best. Young children and unborn children (pregnant women) are more susceptible to high-energy particle radiation because it leads to leukemia years later as their bodies grow (undergoing significant cell divisions). It is critical to protect these individuals first.

In this type of event, a Geiger counter is worth its weight in gold. It can provide a real-time assessment of the radiation threat level, a threat that is essentially invisible. It can also assess the effectiveness of the shelter. The first radiation to arrive will contain the greatest energy and pose the highest risk at the planet's surface. This radiation can be expected with 12-24 hours after the neutrino burst is detected for a supernova within 2,000 light years from Earth. The radiation will show up as surges rather than continuous readings and may spike the meter. There are a variety of types of radiation meters on the market. I would recommend a used civil defense Geiger counter CD V-700. This particular instrument is constructed using basic 1960's electronic components (resistors, diodes) that will be less vulnerable to GCR damage. The used units are relatively inexpensive and readily available. The unit measures the low end of radiation exposure and as a result is extremely sensitive. Unlike civil defense meters designed to measure radioactive fallout from a

nuclear explosion, this instrument can detect ionization surges produced by the cascade of collisions from a single high energy GCRs. (One word of caution. Never store the unit with the battery in place. Over several years, the battery will corrode and destroy the Geiger counter. I know this from first-hand experience.)

Generally when a distant supernova appears in the sky, it starts out as a point of light that grows over a period of several months in size before it finally reaches its peak and diminishes. Many scientists assumed the same process would hold for a nearby supernova event. But a nearby supernova event may exhibit a radically different fingerprint. The radiation from a supernova may produce a race condition on Earth. A nearby supernova may be visible for a short time (a few days) before cloud and mist formation produces an opaque atmosphere.

At the beginning of the event, it is important to observe the supernova in detail. Because that information can define naturally shielded safe areas (hills, mountains, ravines) and the daily time period when radiation exposure can be expected. Once this threat window is known, it will be possible to leave the shelter and relocate home and construct a radiation basement shelter. Very high energy GCRs in the TeV energy range will travel only slightly slower than the speed of light and will generally travel in a near straight line. Therefore, line of sight to the supernova is a strong approximation to the threat vector. The exposure time will begin shortly after the event is observed and will last for several weeks or months. The exposure area and exposure times will vary as the Earth makes its yearly procession around the sun. As the energy levels drop off, a point will be reached where the surface radiation no longer presents a significant safety risk and shelters can be abandoned completely. The GCRs will continue to bombard Earth for several hundred years as their energy levels taper off to the lower cut-off (100 MeV) but the GCRs will primarily affect the atmosphere during that period, producing abnormal weather patterns.

Other Considerations

Several infrastructure elements that rely on electronics may be threatened by the radiation damage. In order to ensure operability of these electronic systems, the equipment must either be shielded or redesigned. During the radiation threat window, shield the elements using mass shielding techniques.

Society has become very dependant on trucks, automobiles and motorcycles for transportation. Unfortunately ever since 1985, these vehicles have incorporated into their design a greater reliance on integrated circuits, computer chips and transistors, primarily for pollution control. These components are susceptible to direct radiation damage. If this transportation infrastructure is severely crippled by particle radiation from a supernova event, an option is available. An experienced ace automotive mechanic has the knowledge to modify many of these vehicles to defeat the failed electronic systems and place the vehicle back in service. I chatted with a local mechanic and he feels greater than 70% of the vehicles can be modified successfully. His approach would be along these lines:

- * engine computers – identify and patch all essential functions (headlights, break lights, ignition, etc.) on the wiring harness and eliminate everything else.

- * electronic ignition – if the vehicle has a distributor, a work-around is possible. But if the ignition is totally electronic, a conversion is not feasible.

- * fuel injection system – replace with carburetor.

- * anti-lock breaking system – unhook wires and generally unit should work on standard brakes.

- * electronic automatic transmission – overdrive could be unplugged. Overdrive will be lost but the other gears should still be operative.

- * computer controlled active suspension – he feels that this is not an issue.

- * electronic keys – most electronic keys contain a hard manual key backup.

Vehicles vary and the approach detailed above will not work on all vehicles, therefore a competent & knowledgeable mechanic should perform all modifications. During this emergency, governments should temporarily suspend laws that would inhibit this conversion and facilitate the immediate restoration of the transportation infrastructure.

Infrastructure that relies on modern electronics is vulnerable. If the infrastructure goes, we need to reboot civilization. Our present system of cell phones, Internet, television, radio will cease. Communications will digress swiftly down to rumors and word-of-mouth. I feel the importance that every individual maintains a hardcopy of this “Supernova: Disaster Preparedness Plan” and “The Ice Age Cometh” because after a nearby supernova, computers may be inoperative. For this reason, I have provided these files in “pdf” format for ease of printing. One of the critical first steps in rebooting civilization is to bring newspapers back on-line and begin the process by publishing these two reports. These documents will provide insight into the disaster and pull civilization out of the rabid fear let loose in dark ages.

During the shelter stage store adequate food and water supplies. Have an alternative method for cooking available. Have an alternative method of managing sanitation/human waste such as a bucket toilet available.

In order to keep track of the radiation threat window, I recommend the shelter inhabitants have a manually wound clock or watch available. These are becoming difficult to find today. I would also suggest a manually powered flashlight (no batteries). The batteries in conventional flashlights will be dead after several days/weeks of heavy use. Fortunately there are several designs on the market today including flashlights with hand cranks, flashlight operated by hand squeezes, and flashlights operated by shaking. My favorite is the top-of-the-line flashlight in the “Nightstar” line produced by Applied Innovation Technology, Inc. This flashlight generates electricity by shaking a rare earth magnet within a coil of wire. The electrical energy is stored within an advanced *Gold-Film* capacitor. The capacitor powers a StarCore™ Light Emitting Diode (LED), which produces white light (10,000 mcad) and is rated for 100,000 hours. Approximately 30 seconds of shaking provides sufficient energy to power the flashlight for 20 minutes. The device is ruggedized and should last for several years during this type of emergency.

Altitude affects radiation dosage. The atmosphere is less dense at higher altitudes and therefore provides less shielding against GCRs. This will produce a higher radiation dosage. Typical cosmic radiation levels at sea level in Germany are 0.3 mGy/year. This radiation dose doubles with every mile increase in altitude above sea level. Air travel will be severely restricted due to high levels of cosmic radiation. Cities at higher elevations, such as Denver generally will be exposed to a greater radiation threat than cities along the coast.

Several natural planetary protection features have evolved over billions of year on the planet. Some are currently known while others will become evident during the next supernova event. GCR radiation will produce extensive cloud cover, which is a natural planetary protection device. Water is an effective shield for lifeforms from particle radiation. Adding a blanket of water over the surface of the Earth enhances the Earth’s atmospheric shielding. This clamps down and limits the penetration of GCRs. (During the shelter stage, dark clouds may provide a pressure relief to individuals cooped up in shelters for extended periods of time. When the sky is pitch black from an impending heavy rainstorm, individuals may be able to leave their shelter for a short period, relying on the water in the clouds for radiation protection.)

Our world is complex and intricately beautiful. Because our lifespan on this planet is but a heartbeat, we generally do not see these intricate mechanisms in motion. One of the adaptive features engineered into nature that comes into play during a nearby supernova event is a chemical defense mechanism in plankton. Phytoplankton are tiny single cell floating plants that inhabit the upper layers of lake and ocean water around the globe. These organisms are vulnerable to damage from ultraviolet (UV) radiation. A nearby supernova event will destroy the ozone layer that protects Earth from solar UV radiation. Once this protective shield is gone, the Earth’s surface will be flooded with UV radiation. Phytoplankton have evolved a natural survival mechanism. Under high ultraviolet light, phytoplankton produce dimethyl sulfide (DMS). DMS acts as cloud condensing nuclei seeding formation of mists and clouds that will partially block and limit damage. This process is incredibly rapid, measured in days.

FAMINE

Ancient saying "Never eat your seed corn."

In the early 1970's when I lived in California, I heard on the morning news a rumor that United States would soon experience a severe shortage of toilet paper because of major plant closings. After work on the way home, I stopped at the local grocery store to pick up food. As I entered the store, I encountered a scene that resembled the end of the world. There were rows of shopping carts filled to the brim with toilet paper. Elderly ladies were patiently waiting their turn in line to pay for their hoard. The aisles normally containing toilet paper were stripped bare. Of course these rumors were false. There was no shortage. But that didn't stop the panic and the run on toilet paper. At the onset of a sudden global cooling event, I expect similar panic and hoarding. The shelves of food in every grocery store across the land will be laid bare in a day.

During the onset of the past global cooling events (Dark Ages, Little Ice Age), the adverse weather produced massive crop failures and a Great Famine. Much of the Earth was suddenly impacted with a lack of food and starvation. As the famine progressed, individuals migrated fleeing the crisis areas seeking employment and food. Because of deep starvation, these masses began to rely on strange diets (field grass, discarded spoiled food, blighted grains, bark etc.). This diet led to uncontrollable diarrhea, acute fevers, loss of vigor, throat lesions, sensitivity to cold (chills), loss of coordination and balance. Once enfeebled, disease and pestilence quickly took hold and a great many people died in the first few years of the global cooling event (~ 10% of the population).

My personal opinion is that farming techniques in the United States have advanced to the point that the country could weather a Great Famine at the leading edge of a global cooling event. That doesn't mean that there will not be massive shortages, panic, inflated prices, and the need to alter our diets for a few years to survive. Good management of this crisis can avert major famines in the United States.

I expect the store shelves to be stripped bare and then restocked and then stripped bare again. Each time the variety will be diminished. Eventually food supplies will fall to their lowest common denominator grains (cornmeal, oatmeal & flour) and bread.

At the onset of a global cooling event, farm production will be greatly diminished. But it will not be a total shutdown. Some areas will be able to produce one year while other areas the next.

One of the greatest unknowns will be the stability of the infrastructure. We have become very dependant on a complex infrastructure, which is vulnerable to damage from very high-energy particle radiation. If the infrastructure damage is severe, food processing and distribution will consequently be severely impacted.

So how does one survive in a Great Famine? The answer lies in the fact that not all food sits on shelves in supermarkets. The bulk of the food in this country is in grain silos. It is the grains we feed to cattle and other livestock.

Most of the world lives on grass seeds. Wheat, oats, rice, millet and other cereals are grasses. In the United States, corn is a natural choice for food during famine conditions because of its abundance. The United States produces vast quantities of grains. For example in 1997 the U. S. farmers harvested 8.6 billion bushels of corn, 2.2 billion bushels of wheat and 2.5 billion bushels of soybeans. This production equals approximately 333 million tons.

According to the UN, the minimum daily requirement for food is 2,300 calories per person. Grain meal provides between 1200-1700 calories per pound. **One ton** of grain will supply the needs of **one individual for three years**.

Corn is lacking in two essential amino acids, lysine and tryptophane, and is below the nutritional requirements for non-ruminant animals and humans. For this reason, a diet of corn must be augmented with beans (such as soybeans) or rice.

Grains in this nation are stored by farmers and by organizations such as farm cooperatives, and Feed & Grain stores. The quickest method to obtain a large quantity of grain is to drive up to a farm coop and have them load bags of grain onto your pick-up truck. A fifty-pound sack of corn is currently running \$6.10 at the local Feed and Grain. Large shipments can also be delivered to any destination you request in bulk form. In my locale, a ton of corn can be delivered to my home for \$104 with a \$1 per mile delivery fee.

I decided to run an experiment and tap into this food source. After all, how difficult could this be? I traveled to the nearest Grain and Feed Store and purchased a fifty-pound sack of cracked corn. I soaked a handful of corn in a pot filled with boiling water to soften it up. After two hours it was still as hard as stone. Then I soaked the corn overnight in room temperature water. It was still tough as nails the next day. I took a few pieces and tried to chew on them. After about 5 minutes my saliva softened the pieces a little. I have powerful jaws and you need them if you try to eat corn this way. Also it is good to have a resident dentist on call 24-hours a day. So far I would categorize this experiment as a miserable failure. I was getting desperate. I took some corn into the garage, found an old used heavy metal pot, took out my hand sledgehammer and started to work. After about 30 minutes, I reduced a cup of corn into a fine powdered corn meal. Success! All told, I probably burned more calories than what was present in the corn. I went back into the house and used the corn flour to make tortillas. The end-product looked more like a UFO shaped pancake. I ate some. It was edible. I gave some to my youngest daughter, Carrie. She ate it and afterwards complained that I was trying to poison her.

Lessons learned:

1. Extremely important if you ever need to tap into this basic food source to purchase a reliable and durable hand operated grain mill. I purchased a Country Living Grain Mill and a Bean/Corn Auger Accessory. Other examples of good mills are a Heidelberg Grain Mill, Family Grain Mill, and Silver Nugget Mill. All of these may be a little pricey but the quality is there. Whatever you purchase must be capable of grinding corn. That is why the optional Bean/Corn Auger is a requirement. The U.S. produces considerably more corn than wheat. I do not recommend an electric grain mill because the electrical infrastructure may be damaged. Also it would be beneficial to have an extra set of grinding plates because the plates will wear out over time. I feel a reasonable goal is 3 years of operation without access to additional parts.
2. Purchase only whole corn, not cracked corn. The cracked corn has particles of dirt and other residue intermixed which is difficult to remove. But with whole corn, you stand a better chance of cleaning the corn before it is ingested. Also whole corn is more difficult for the critters to consume.
3. Purchase a cast iron tortilla press. It is better to make a tortilla that looks like a tortilla otherwise you children will look at you funny during meal-time.

I had a conversation with a close friend, Maria Crays, who made tortillas from scratch and remembers how it was done in the old days in Mexico.

How to Process Corn into Tortillas

Corn meal is too brittle to be fashioned into tortillas. The following method for making corn tortillas was used in Mexico over a century ago.

- * Mix ½ cup of lime with ½ gallon of water.
- * Place one gallon of dry corn kernels in a large pot and add the limewater until the corn was completely covered.
- * Place the pot onto a fire and bring the corn/water to a boil. Slowly cook the corn for approximately 30 minutes until the outer skin is soft enough to peel off.
- * Take the pot off the stove. Add more limewater to completely cover the corn. Set the pot aside overnight.
- * In the next morning, drain the limewater from the pot and rinse the corn with clean water.
- * Coarse grind the corn in a hand grain grinder.
- * Take the ground dry paste and add water.
- * Regrind the moistened paste in the hand grain grinder set to fine grind.
- * Take the fine paste and shape them into balls about half the size of an egg.
- * Use a tortilla presser to make flat tortillas.
- * Fry the tortillas on a fry pan. No oil is required.

A conversation about lime (calcium oxide) then ensued. One source of lime is Pickling Lime that may be purchased in grocery stores. This lime is food grade but may contain salts and anti-caking agents. In an emergency situation, lime is a common building material. It is used in cement construction and can be bought in large bags at a building supply store. Ag-lime can also be found in fertilizer stores. These types of lime are coarser. They are an industrial grade. In addition to lime, it may contain some heavy metals, some combustion byproducts, and some fly ash.

Lime is manufactured from limestone. The method used to manufacture lime in the small villages in Mexico during the 19th century is as follows:

- * Dried cow dung was collected and placed on the ground to form a circle.
- * A layer of limestone was placed over the layer of dung.
- * Another layer of cow dung was collected and placed over the limestone.
- * Another layer of limestone was placed over the dung.
- * This process was repeated until a large mound was formed.
- * This mound was set on fire.
- * The limestone would heat up until it was white hot.
- * The stones were collected and placed in a burlap bag.
- * Cold water was poured over the burlap bag, and the hot rocks exploded into a fine powder of lime.

Other types of fuel, such as wood or coal, could be used to manufacture lime. In addition to tortillas, corn meal can be processed into cornbread, muffins.

I have described one of the lowest basic denominators for surviving a Great Famine. I believe the U.S. has sufficient grain supplies to carry us through a Great Famine lasting 3 years. Many grains will need to be diverted from animal feed into cornmeal and flour. This will require thinning our herd of livestock and resorting to a bland diet for a few years. But it is far better than the horrors of starvation. One unknown is the level of infrastructure damage. Our infrastructure is very dependant upon electronics. Surprisingly during the onset of the last major cooling event 700 years ago, the Little Ice Age, their low-tech infrastructure was severely damaged, which compounded the effects of the famine. Rinderpest flared up in oxen destroying much of the herds throughout Europe. Oxen were used in farming to plow the fields and in transportation to move the grains to the mills and then to market. If our modern infrastructure sustains similar damage from radiation, the U.S. will have adequate grain supplies but may find it difficult to transport the grain to processing centers and then onto the major population area.

Food Storage

The weather after the onset of a nearby supernova event will severely limit crop production for several years and produce a Great Famine. But after that period the weather will calm down and enter a cyclical stage. In the bad years, famine will reoccur.

Setting aside a store of canned goods (~1,000 quarts/person) will take the edge out of the lean years. Home canning of fresh vegetables and meats is an excellent method of storing foods. With a good pressure cooker, adequate canning jars, and energy (electricity or natural gas), thousands of quarts of food could be set aside quickly. This will provide some needed variety to the bland diet of grains. Several years back, when my wife Maria was in traction due to a leg injury, I canned 100 quarts of green beans in one day. That rate provides an indicator of processing capacity for one pressure cooker. Store powdered milk, salt, canned fruits, to add variety and nutrients into the diet. Store several gallons of cooking oil per person for fatty acid requirements.

Corn kernels if they are dried sufficiently below the moisture levels in which mold forms can be stored for several years at room temperature. Grains should be protected from moisture and insects & other varmints. Heavy plastic trash bags inside lidded trashcans are one means of dry corn storage. Vacuum-sealed storage of dried corn can last decades.

Another food-source that could be tapped is roots and edible tubers (potatoes, beets, carrots, etc.). Over the years, farmers have successfully stored potatoes in cool, dry locations (such as root cellars) for a year or longer. I recommend this approach be coupled with another process to further extend the shelf life, gamma ray food irradiation. Irradiation is a process in which radiation is applied to food products to destroy insects and microorganisms that cause food to spoil quickly. Irradiation will also prevent potatoes from sprouting. I recommend the irradiation process be performed in an oxygen excluded environment and an environment where the temperatures are kept very low in order to minimize the loss of natural vitamins. Irradiated potatoes and beets could be double wrapped in large plastic trash bags and stored underground. Carrots are best stored in sand. Roots and edible tubers must not be allowed to freeze. Irradiation of meat followed by vacuum packaging could produce large quantities of shelf stable meat without the need for refrigeration.

PLAGUES

The primary means that multicellular organisms utilize to repair radiation damage is to identify and discard the affected cell and manufacture replacements. But single cell organisms do not have that luxury. As a result, many single cell organisms have evolved very complex and redundant repair mechanisms that ensure their survivability even under higher levels of radiation damage. The most resistant organisms are single-stranded viruses, followed by double-stranded viruses, bacteria, algae and yeast. Under nuclear radiation, many of these single cell organisms will mutate and survive. The genetic variations will spawn new mutated single cell organisms that are extremely virulent and deadly especially to the future host they infect. That is why great plagues are intertwined with the great famines at the onset of major global cooling events.

Sensitivity of Prokaryotic and Eukaryotic Organisms to Radiation

Name	Species	D ₀ (Grays)
T1-phage	Virus	2600
<i>Escherichia. coli B/r</i>	Bacteria	30
<i>Bacillus subtilis</i> cells	Bacilla	33
<i>Saccharomyces cerevisiae</i>	Yeast	150
<i>Chlamydomonas</i>	Algae	24
Human	Human	1.4

D₀ is defined as the dose necessary to reduce survival to e⁻¹ (37%). Gray is a unit of measure defined as 1 joule per kilogram of absorbed radiation. Source: Life under Conditions of Ionizing Radiation by Christa Baumstark-Khan and Rainer Facius.

This table shows that typically viruses, bacteria and bacilli can survive the damage from greater ionizing radiation exposure than many multicellular organisms. But very high energy GCRs will mutate these organisms producing new and lethal strains.

The plagues did not just coincide with past global cooling events but were directly caused by the radiation from the supernova. Two examples, which appeared at the onset of both the Dark Ages and the Little Ice Age, are the Yersinia Pestis bacillus, and the Rinderpest virus. Both organisms appear to be significantly mutated by particle radiation during those times.

Rinderpest

An extremely virulent variant of Rinderpest struck animals immediately at the onset of the Little Ice Age in 1315 AD producing an animal plague that wiped out vast herd of oxen, sheep, goats, camels, buffaloes, yaks, etc. In several large herds, only a couple animals survived. This plague was also present during the Dark Ages.

The recommended approach to combating this plague is for all sick or exposed animals to be immediately slaughtered and disposed of appropriately. This involves burning and burying carcasses. A nationwide quarantine should be put in place when the disease is detected and the importation of animals from the infected areas should be prohibited. I also recommend the implementation of mass vaccinations targeting the new strain of rinderpest in vulnerable animal herds.

Black Death

Yersinia Pestis is a pathogen that has undergone large-scale genetic flux. Global cooling at the beginning of the Dark Ages began in 536 AD. An outbreak of the Bubonic Plague struck Constantinople 6 years later. It was caused by a very deadly variant of the *Yersinia Pestis* bacillus that used fleas (and rats) as a plague transport mechanism. This plague was referred to as the Plague of Justine. As it swept from the Middle East to the Mediterranean Basin, 50% of population perished.

Global cooling at the beginning of the Little Ice Age began in 1315 AD. An outbreak of the Bubonic Plague struck the Chinese Gobi Desert 15 years later. This deadly variant of the *Yersinia Pestis* bacillus killed 35 million Asians and spread westward where it killed 1/3 of the European population. The plague was known as the Black Death. It came in three variants: bubonic plague, primary septicemic plague, and the pneumonic plague. To date, this deadly bacillus has been responsible for 200 million human deaths.

The recommended approach for dealing with this plague is to implement infectious controls on travel and commerce to limit the spread of plagues. The Centers for Disease Control (CDC) recommends the use of streptomycin or gentamycin at the onset of the disease, but a number of other antibiotics are also effective. A mass immunization using a killed live bacillus may be required to combat this threat.

Malaria

Another type of plague occurred during past global cooling event. But this time instead of resulting from genetic mutation, it was due to the GCR induced extensive flooding. The heavy rainfalls produced new swamplands across the globe. These swamps became breeding grounds for major mosquito borne diseases including malaria. Major malaria outbreaks occurred across Europe during the Little Ice Age.

Malaria is transmitted by mosquitoes. When a mosquito bites an infected person, it ingests microscopic malaria parasites found in the person's blood. When the mosquito then bites another person, the parasites go from the mosquito's mouth into the person's blood. Within a human, the parasite goes to the liver, replicates, and moves into the bloodstream, where it attacks red blood cells for their hemoglobin. Toxins from the parasite are then released into the blood, making the person feel sick. Malaria produces fever and flu-like illness, including shaking chills, headache, muscle aches, and tiredness. Nausea, vomiting, and diarrhea can also occur. Malaria in children can produce anemia, jaundice, kidney failure, seizures, mental confusion, coma, and death. The World Health Organization estimates that 300-500 million cases of malaria occur and more than 1 million people die each year from malaria, mostly children in sub-Saharan Africa.

Recommended Approach

Global cooling events are intertwined with devastating plagues. The U.S. will rely very heavily on the medical infrastructure to combat the plague threat. Modern medical equipment is vulnerable to radiation-induced damage. The medical infrastructure used to combat plagues and epidemics must top the list of vital equipment critically requiring mass shielding.

We have developed a great weapon to combat many of these plagues, but in our great wisdom, we have banned its use. The weapon is an insecticide called DDT, short for dichloro-diphenyl-trichloromethylmethane. DDT is very effective at killing parasites (fleas, mosquitoes, lice, mites and ticks) responsible for majority of deadly plagues experienced by mankind (bubonic plague, malaria, typhus, yellow fever, dengue fever, sleeping sickness, encephalitis, elephantiasis, leishmaniasis, and yaws). DDT when used in moderation does not pose a significant health risk. The health consequences of using DDT were greatly exaggerated by the environmental community and as a direct result the use of DDT has been essentially banned worldwide. As a result of this insecticide ban, a million people each year are condemned to a

needless death. Most of these are children. DDT was credited with eradicating malaria in Western Europe and North America.

When I was a youngster in Chicago, I went outside and played in fog banks of sprayed DDT. Forty-five years, I still cannot discern any ill effects. On the other hand, I have been immunized against the bubonic plague using a killed live bacillus. This was part of the immunization routine in boot camp in the Air Force. This shot was the most powerful immunization, I ever experienced. Generally, I have a strong constitution. But this shot made me woozy and the effects were immediate. It not only affected me, but also affected my comrades. I can still remember the sound of their skulls cracking as they hit the pavement, fainting from the after-effects of this immunization. The small pox shot is trivial in comparison to the very potent bubonic plague shot. If the effects from killed remnants from this bacillus can have such a profound affect on my constitution, then the effects from a live bacillus should be greatly feared. During the Dark Ages and the Little Ice Age, the bubonic plague produced death to such a scale that approximately 50 percent of the population perished. The human race would be very foolish to not utilize one of its greatest weapons (DDT) to combat a new wave of genetically-mutated parasite-transmitted plagues arising from the effects of particle radiation from the next nearby supernova event.

CROP PRODUCTION

A global cooling event will severely stress the farming industry. Constant rainfall, colder temperatures, continuous cloud cover and a shortened growing season will produce a major drop in food production. This will lead to global famines. This will not only affect mankind but also domesticated livestock due to a severe lack of livestock feed. I recommend we reduce our herds of livestock and channel grains towards human consumption at the onset of a global cooling event. Only breeding stocks should be maintained during the initial years. It is of great importance for farmers to be able to reconstitute their livestock. This may require sheltering their breeder stock from particle radiation exposure using mass shielding.

The rain will leech nitrates from the soil further diminishing farm productivity. During past global cooling events, oats fared better than wheat and pigs fared better than cattle. Genetically engineered grains may overcome some of the problems of shortened growing seasons, floods, and droughts.

Galactic cosmic rays are a product of a supernova. The initial burst of highly energetic GCRs will be minimally affected by the Earth & Sun's magnetic fields. It will punch its way right into the Earth's surface. But this phase is short lived and will dissipate within the first 10 years. This burst will be responsible for producing the Great Famine. But after this initial surge, the GCR energies will drop off slowly and the Earth and Sun's magnetic fields will begin to function as effective shields in blocking part of the remainder of the radiation stream. When GCRs enter our solar system, they must overcome the outward-flowing solar wind. The magnetic field transported with the solar winds deflects and thereby attenuates the lower energy particle flux rate that penetrates the heliosphere. The intensity of the solar wind varies according to an 11-year solar cycle. The GCR flux rate of incoming radiation is peak during the Solar Minimum (period with least amount of solar flares) and is at its lowest level (blocked) during Solar Maximum. The average eleven-year cycle of solar activity can be divided into four inactive years (around Solar Minimum) and seven active years. The Earth will experience a repetitious cycle of 4 colder years (lean years) correlated with Solar Minimum followed by 7 warmer years (tolerable crop years).

After the lean years of the Great Famine, governments should restock their strategic reserves (grains, corn, beans, rice, etc.). This is in preparation for the cyclical pattern of famines that will plague the Earth for the next several hundred years. This is also the time to reconstitute the herds of livestock.

FLOODING & STORMS

The initial thought that strikes the mind with the mention of the word *Ice Age* is *ice, snow, and shivering cold*. But in reality, the onset of a global cooling event is generally characterized by a prolonged period of heavy rainfall and constant dreary weather. Individuals who lived through the beginning of the Little Ice Age compared it to the time of the Biblical Flood because the rainfall was constant for months.

The inception of global cooling will create many violent storms that will repeatedly blast the coastlines and produce major inland flooding. It is not desirable for the government to encourage its citizens to construct housing and infrastructure along these vulnerable areas. But unfortunately, that is exactly what the U.S. government is doing with the National Flood Insurance Program. This program provided government subsidized flood insurance with unnaturally low premiums. This program essentially places the risk on the government lifting it off the shoulders of those that have made the risky decision to build in a highly vulnerable area. I suggest the government terminate this subsidized insurance program.

The U.S. government should encourage farmers to take risks during the inception of a global cooling event. By maximizing crop production, U.S. farmers could not only feed its citizens preventing major famines but also minimize the impact abroad. Since some of the most productive farmlands are bottomland, which is very vulnerable to flooding, the government should help to underwrite farm equipment and seed/fertilizer losses during this event. It is also important for the government to provide farmers with accurate space weather forecast.

The U.S. can expect an uptick in tornadoes. Therefore the government should strongly encourage the construction of storm/tornado shelters in Midwest along with advanced warning systems.

The massive flooding will threaten many grain silos, which contain the very grains that the U.S. will depend upon to survive the Great Famine. As this threat materializes, I recommend the government coordinate the move of vulnerable grain storage to high ground.

COLD WEATHER

Ever since the invention of clothing and shelter, man has been fairly successful in shielding himself from the effects of extreme cold weather. My brother David lives up in Alaska and experience temperatures that drop to -50°F in the winter. He takes the cold in stride and manages to survive the winters. (He even went outdoors and rode in a snowmobile at -50°F . As a result, he experienced wind chills of -100°F . In retrospect, he now considers that action a little foolish and has made up his mind to be a little more cautious in the future.) The drop in global temperatures that occurred during the past two global cooling events (Dark Ages, Little Ice Age) resulted in a drop of only a couple degrees Fahrenheit. In general, the effects of the cold should be easily survivable.

Infrastructure

Several years back, a winter storm descended upon a friend of mine, Tom Bishop. The temperatures dropped to -25°F . During the night, he lost electricity. He heated his house with fuel oil. Without electricity, the furnace shut off. When the electricity was restored an hour later, the fuel oil had coagulated into a substance that resembled Jell-O. He was unable to restart the furnace. He woke his wife and children and loaded them into the car and made his way in the storm to his mother's house. But the car's tires were bad, and he blew two on the way. What normally would suffice as an inconvenience, a one-hour loss in electricity, can easily turn into a life and death struggle.

During the initial burst of high energy GCRs at the beginning of a major global cooling event, the infrastructure, which we have become to rely upon completely can sustain damage. This infrastructure includes the systems used to heat our homes and businesses (natural gas, propane, fuel oil, electricity). I advise that individuals maintain the capacity to survive temporarily during the loss of this infrastructure. Bedding (such as down comforters), sleeping bags temperature rated for 0°F or below and thermal underwear are important reserves should the infrastructure fail.

Starvation

During starvation, the human body can become hypersensitive to cold. The layers of fat that normally protect the body are gone. Individuals that survived the onset of the Little Ice Age recorded the severe pain and agony experienced by the malnourished throughout Europe. They found it difficult to describe in words the evening nightmare, the mass of human beings wailing in the dark cold that left an indelible mark on survivors.

GLACIAL PERIOD

The end of an Interglacial Period and the return to full Ice Age Glacial temperatures is a **very severe** form of a global cooling event. Moderate cooling events drop the global temperature a few degrees. But deep cooling events are dramatically more severe. Fluctuations of 25° F (14° C) in global mean temperatures have occurred over the past 800,000 years. A glacial period is spawned by decades/centuries of extensive cloud cover and rainfall. Great famines will be the norm. Life will have to hold on by a thread.

The Earth is presently coming out of the effects from the last global cooling event (the Little Ice Age). Current low GCR flux rates produce fewer low clouds and therefore a warmer climate. That is why the temperatures have been on the rise during the past century. These are good times. The Earth is warming. Enjoy them! But the Earth is presently within a Great Ice Age, which will continue for several million years. Another nearby supernova will throw us back into a period of global cooling.

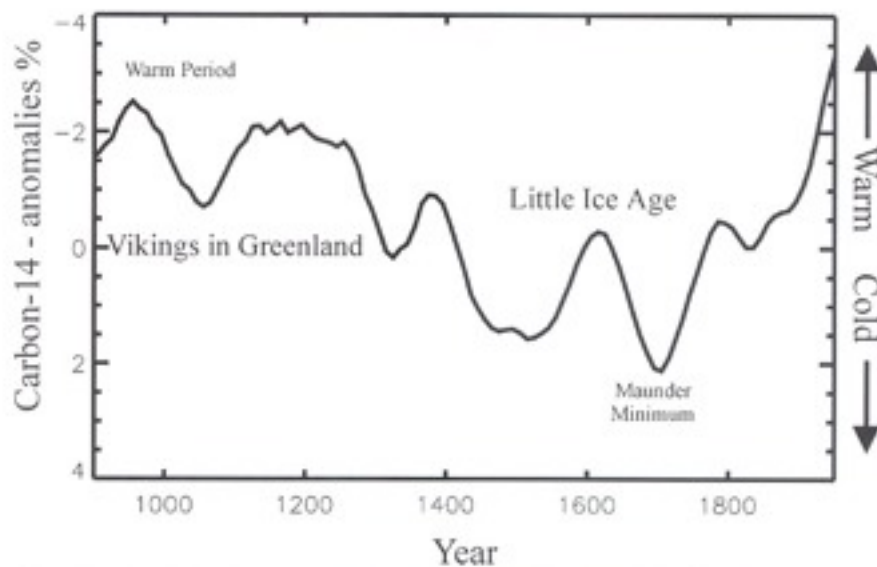

Figure 3. GCR flux rate over the past 1000 years as measured by variation in the C^{14} production rate on Earth. C^{14} is produced through nuclear interactions of cosmic ray particles in the atmosphere. **Source:** Marsh, N. and Svensmark, H. (2000) *Space Science Review* **00**, 1-16.

Earth's proximity to the supernova, and the strength of the heliomagnetic and geomagnetic fields dictate the breadth and depth of the next global cooling event. We might experience a short period of global cooling similar to the Dark Ages (536-545 AD), a moderate period of global cooling similar to the Little Ice Age (1315-1850 AD), or a return to a full Glacial Period lasting 50,000 years or more. A nearby supernova event will produce a major cooling event in both the Northern and Southern Hemisphere simultaneously.

One might think of the Earth as protected by three shields. The outer shield is produced by the Sun's magnetic field. The next layer in is the Earth's magnetic force field. The inner shield is the Earth's atmosphere. When this outer shield breaks down as it did during the Maunder Minimum (1645-1715 AD), mid-energy GCRs from the 1315 AD supernova were able to penetrate to the lower Earth's atmosphere. The GCR flux rate shot up dramatically and global temperatures reached their coldest point. The maximum glacial stage occurred in the 1750's. Glaciers became more widespread than at any time since the beginning of the Holocene. But when the Earth's magnetic field breaks down, the effects can throw us back into the full fury of a Glacial Period.

The Earth is extremely vulnerable to supernova events during a magnetic field reversal. Earth's magnetic shield is the strongest where the Earth is the most vulnerable, at equatorial latitudes. GCRs interacting with the atmosphere in the Polar Regions produce very little cloud formations because the moisture generally exists in frozen form, which drives humidity levels towards zero. But tropical and subtropical temperatures combined with ocean moisture are a breeding ground for great and powerful storms. The equatorial regions are generally the hottest and most humid on the planet. A nearby supernova event during a magnetic field reversal could easily push the Earth back into the full fury of an Ice Age. The last two transitions from Interglacial to Glacial Periods occurred during local magnetic field reversal.

Current Status of Earth's Magnetic Field

When the Earth's magnetic field is strong, it is characterized as a dipole with a north and south magnetic pole on opposite sides of the Earth. But when the magnetic field weakens, it often breaks down into quadrupoles, octupoles and local magnetic field reversals. The appearance of this complex structure allows minipoles to effectively cancel out the Earth's magnetic field reducing the overall magnetic field strength to 10% or below. During this phase the local fields can reverse polarity several times before they restructure back into a strong dipole configuration. The restructuring can lead to a global polarity reversal or to a restoration of the normal state.

The intensity of the earth's magnetic field has been declining. Scientific analysis of ancient pottery has shown that the magnetic field strength has declined 50% in the last 4,000 years. Recently, the decline has become very steep and pronounced. The decline in field strength at the equator has fallen 4.5% during the last century. Most of this decline occurred during the last 25 years. Using the International Geomagnetic Reference Field (IGRF) data set, the magnetic field at the equator in Open Ocean shows a decline of 1.7 percent in intensity since 1980. (*Geomag program, IGRF dataset, latitude 0 degrees, longitude 180 degrees, years 1980-2005, a decline from 34,824 to 34,246 nanoTesla (nT)*).

Dr. Heikki Nevanlinna, Research Professor at Geophysics Research, Finnish Meteorological Institute, wrote an article in Helsingin Sanomat, the leading newspaper in Finland, July 27, 2002. In the article, he states that the North Hemisphere magnetic pole has moved 1500 kilometers in the past 100 years while the South Hemisphere magnetic pole has moved only 1000 kilometers during the same period. The structure of the Earth's magnetic field is currently asymmetric.

A South Atlantic Anomaly (SAA) has appeared, which is a major depression in the magnetic field strength. The field strength within this depression approaches only 20,000 nanoTesla (nT). (Refer to <http://www.dsri.dk/showpage.php3?id=65>). The SAA is a large local magnetic field reversal in transition.

The fact that Earth's magnetic field is currently asymmetric combined with the fact that a magnetic field depression has formed would lead one to believe that the Earth's magnetic pole components are being restructured.

This weakening of the Earth's magnetic field leads me to believe that the next nearby supernova could produce a rather severe global cooling event. But in my opinion, the magnetic field is still of sufficient strength to preclude bringing the current Interglacial Period to an end and returning the world to a full Ice Age conditions.

Actionable Thoughts on Next Glacial Period

Migration

A return to Ice Age glacial conditions will cause one of the greatest social upheavals ever experienced by mankind. Vast tracts of land will simply become uninhabitable. During the last Ice Age, most of Canada was locked under mile-thick ice sheets. Populations will need to migrate or perish. In the past, migrations forced by an environmental cataclysm were interleaved in warfare. As the ocean recedes, vast tracts of land will be uncovered. This will be new coastal land, some of the most valuable property on the Earth's surface. Seaports will move. Cities will rise up almost overnight while other cities will be abandoned. The appearance of this land will produce a series of land disputes causing hostility between nations. Vast tracts of productive farmland will be buried or decline. This will result in starvation and famines. These environmental changes will produce a new world and a new world order.

In general, using our knowledge of the last Ice Age, we know the areas that will be affected. [Ice Age Map](#)
I recommend countries threatened by this impending disaster negotiate treaties to promote the migration of its peoples. From an American perspective, there is a sonnet that is mounted on the Statue of Liberty that the world should use as a guiding light during these times. It reads

*Give me your tired, your poor,
Your huddled masses yearning to breathe free,
The wretched refuse of your teeming shore,
Send these, the homeless, tempest-tost to me.
I lift my lamp beside the golden door!"*

The Ice Age will threaten the world's industrial infrastructure. Just as the Russians during World War II packed up their industrial infrastructure threatened by the Nazi invasion and moved it to the other side of its vast country almost overnight, the world should facilitate the transfer of this industrial infrastructure. (We do not want to create large refugee camps but rather allow the refugees to become working and contributing members of a new society.)

Territorial Conflicts

The ownership of new territorial lands will be a point of friction and dispute between nations. I recommend we work out agreements to govern control of these new lands. I recommend that current treaties that define international sea boundaries be used as the basis of these agreements. When separated landmasses are joined, I recommend the following rule be applied: let the ocean draw the line. As the ocean recedes revealing new landmass, let the last ribbon of ocean that separates these landmasses dictate the new boundary line between these nations.

Limiting Glacial Effects

The Great Lakes and the Hudson Bay produce lake-effects snow. These lakes become the nucleus of glacier formations. One method of reducing the ice age effects in the U.S. and Canada is to drain the Great Lakes. The heartland of the U.S. and Canada is centered in this region. Many cities have built up along the Great Lakes. These include: Milwaukee, Green Bay, Chicago, Detroit, Toledo, Cleveland, South Bend, Rochester, Erie, and Buffalo in the U.S. and Toronto, Montreal, and Quebec in Canada to name a few. The Great Lakes are a catalyst for glacier formation in North America. Draining the Great Lakes will diminish the intensity of a next major Glacial Period.

Predisposition for Reversing Ice Age

Any new landmass should be treated as government-owned-land. This land should be leased, not sold. When the Earth retreats out of the next Glacial period returning back to an Interglacial, all of this new territory will again be underwater. From the get-go, the Earth should maintain a predisposition for reversing Ice Age conditions. The climate warmth permeating an Interglacial is very beneficial to mankind.

One of the more intriguing questions: Can we pull ourselves out of the Glacial Period? Several hundred years after the supernova, after the energy levels of the GCRs fall off, we may have the ability to undo the Ice Age. We can affect the surface absorption of sunlight by coating the ice with absorptive material. In the winter, our steep driveway becomes coated with snow and ice. We have the habit of taking the ashes from our wood burning stove and coating the ice. This increases the rate the ice melts. Applying this same principal to massive glaciers can produce the same effect. During the springtime of each year, if mankind applies a thin coat of dark ash, soot, coal dust or earth on the ice flows, he will increase the Earth's absorption of solar radiation. This might be done by airdrops similar to water drops used to put out forest fires. This will raise the temperature and promote the return of the Interglacial. Should we attempt this? **Absolutely!**

The backside of a glacial period carries it's own set of dangers. A glacial period is an unstable planetary configuration with vast quantities of stored potential energy. It is like a clock spring tightly wound. This energy must be released in a controlled manner. Otherwise, the spring may unwind all at once producing a great cataclysm and another mass extinction event. When conditions are ripe without man's intervention, this energy can be released very suddenly resulting in a massive ocean surge that washes over continents and producing a Great Flood. For this reason it is critical for the survival of mankind to neutralize this threat. Ice flows should be destroyed in a systematic manner releasing this energy a little at a time. Ice dams should be destroyed quickly, immediately after they begin to form.

LIST OF ACRONYMS & ABBREVIATIONS

~	-	Approximate
"	-	Inch
'	-	Foot
\$	-	United States Dollars
AD	-	Years after Birth of Christ
AMANDA	-	Antarctic Muon And Neutrino Detector Array
BooNE	-	Booster Neutrino Experiment
c	-	speed of light (299,792.458 kilometers per second)
C	-	Centigrade
CD	-	Civil Defense
CDC	-	Centers for Disease Control
cm	-	centimeter
DDT	-	Dichloro-Diphenyl-Trichloromethylmethane
DMS	-	dimethyl sulfide
DNA	-	DeoxyriboNucleic Acid
EMP	-	ElectroMagnetic Pulse
F	-	Fahrenheit
GCR	-	Galactic Cosmic Rays
GeV	-	Billion Electron Volts
gm	-	gram
GPS	-	Global Positioning System
IGRF	-	International Geomagnetic Reference Field
lbs	-	pounds
LED	-	Light Emitting Diode
LVD	-	Large Volume Detector
MeV	-	Million Electron Volts
mGy	-	milli-Gray
mils	-	0.001 inches
mm	-	millimeters
mSv	-	milli-Sievert
nT	-	nano-Tesla
OMNIS	-	Observatory for Multiflavor NeutrIno from Supernovae
SAA	-	South Atlantic Anomaly
SNEWS	-	SuperNova Early Warning System
SNO	-	Sudbury Neutrino Observatory
TeV	-	Trillion Electron Volts
TV	-	Television
UFO	-	Unidentified Flying Object
U.S.	-	United States
UTC	-	Universal Time Code (Greenwich Mean Time)
UV	-	ultraviolet
WW	-	World War